



SolidFlow 2.0

Solid volume measurement



Operating Instructions

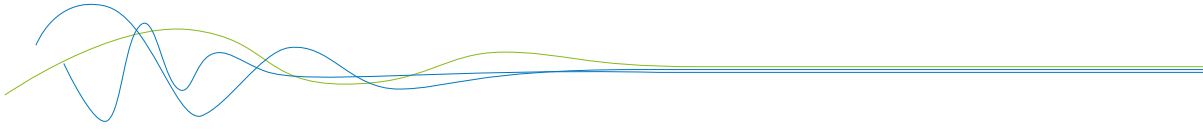

CONTENTS

	Page
1. System overview	3
2. Function	5
3. Safety	6
3.1 Normal use	6
3.2 Identification of hazards	6
3.3 Operational safety	6
3.4 Technical statement	6
4. Mounting and installation	7
4.1 Typical components of the measurement point	7
4.2 Required equipment	7
4.3 Sensor installation	7
4.4 Mounting the transmitter	11
4.5 Use in hazardous areas	13
5. Electrical connection	14
5.1 DIN Rail terminal layout	14
5.2 Field housing terminal layout	15
5.3 Electrical connection C-Box	16
6. Operator interface	17
6.1 Differences between DIN Rail and field housing transmitter	17
6.2 Display	18
6.3 PC interface	20
6.4 One or more sensor system	23
6.5 Menu structure	24
7. Start-up procedure	35
7.1 Basic start-up	35
7.2 Datenlogger function in the software	36
7.3 Adjusting the measurement values	36
8. Error signalling	38
8.1 Compatibility	39
8.2 History of versions	39
9. Maintenance	38
10. Warranty	40
11. Fault clearance	40
11.1 Error codes	41
12. Connection examples	41
12.1 Digital input	42
12.2 Impulse output	42
13. ATEX certificate	43
14. Technical data	46

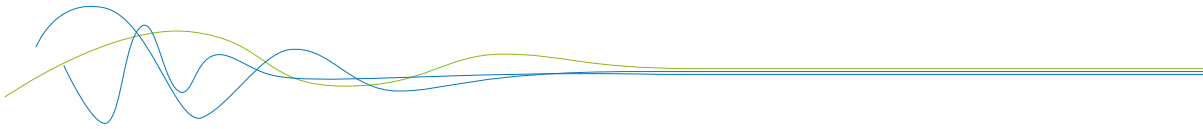

1. System overview

A measuring point consists of the following components:

- Transmitter in the DIN Rail housing or field housing
- Sensor mount for welding to the pipeline
- Sensor (union nut, spacer rings, sealing ring for adjusting to the wall thickness)
- Installation instructions
- C1- or C3-Box (optional)
- Teflon sleeve (depend on application)

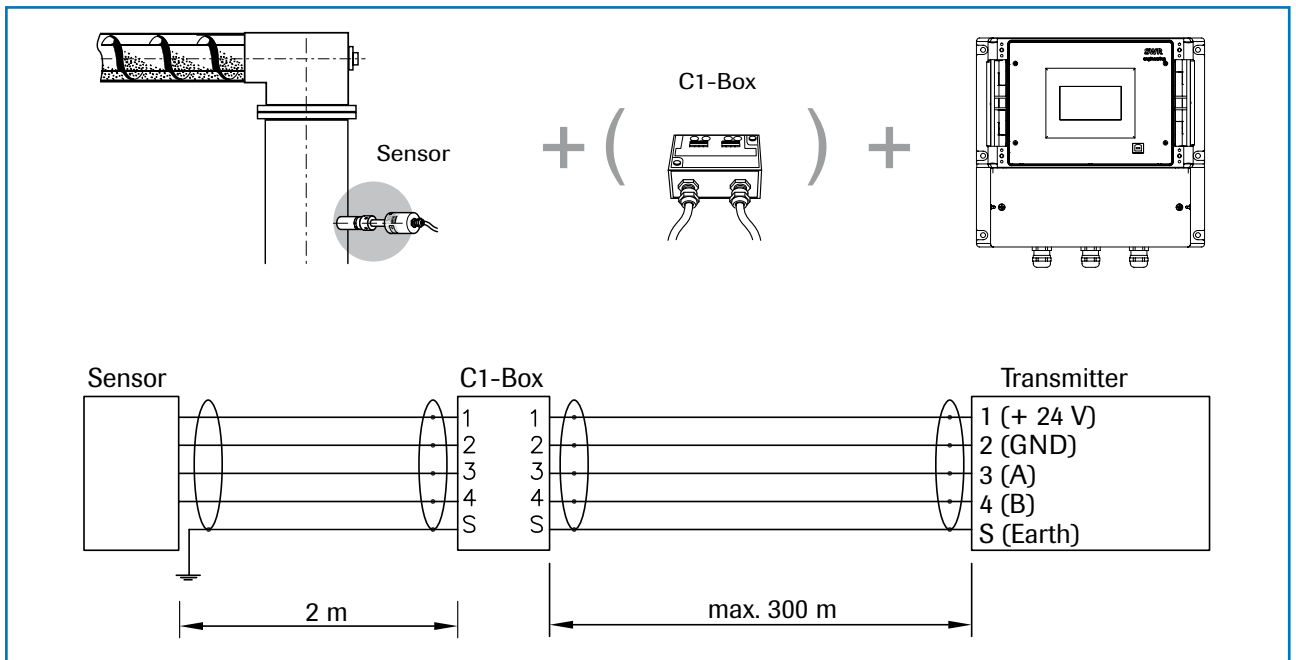

Fig. 1: Overview with C1-Box and field housing transmitter

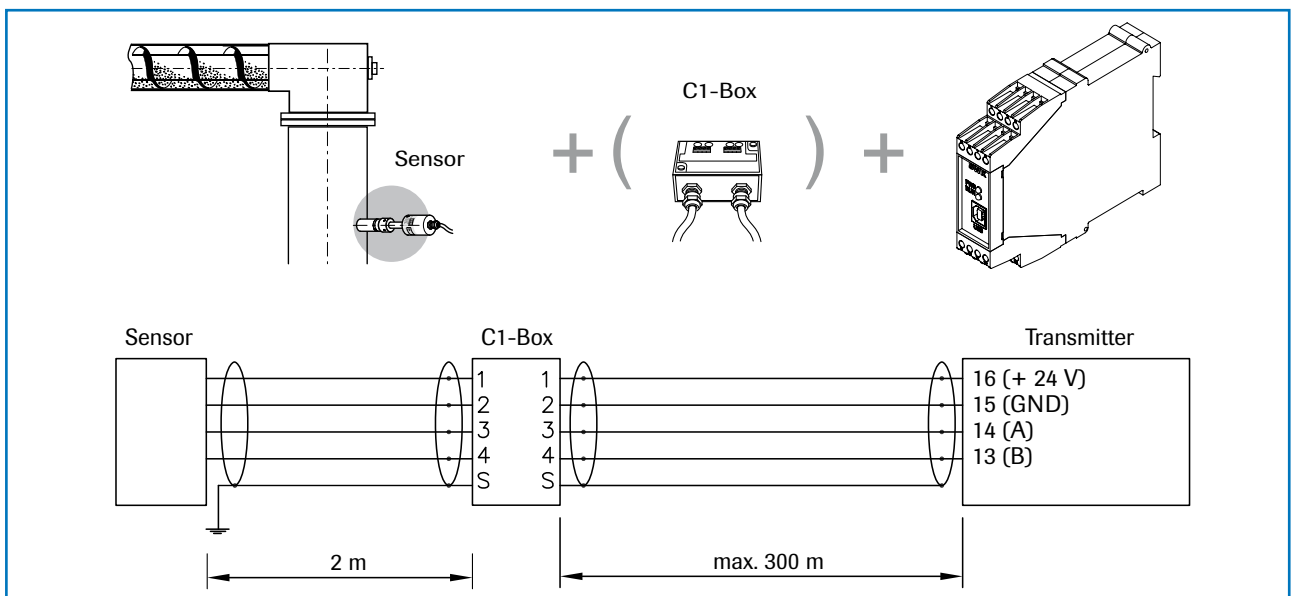
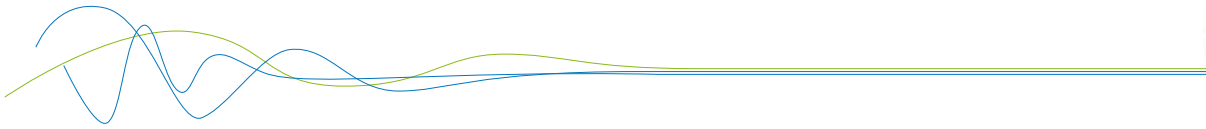

Fig. 2: Overview with C1-Box and DIN Rail transmitter



The system can be equipped with up to three sensors. Different C-Boxes (C1, C3) are used accordingly.

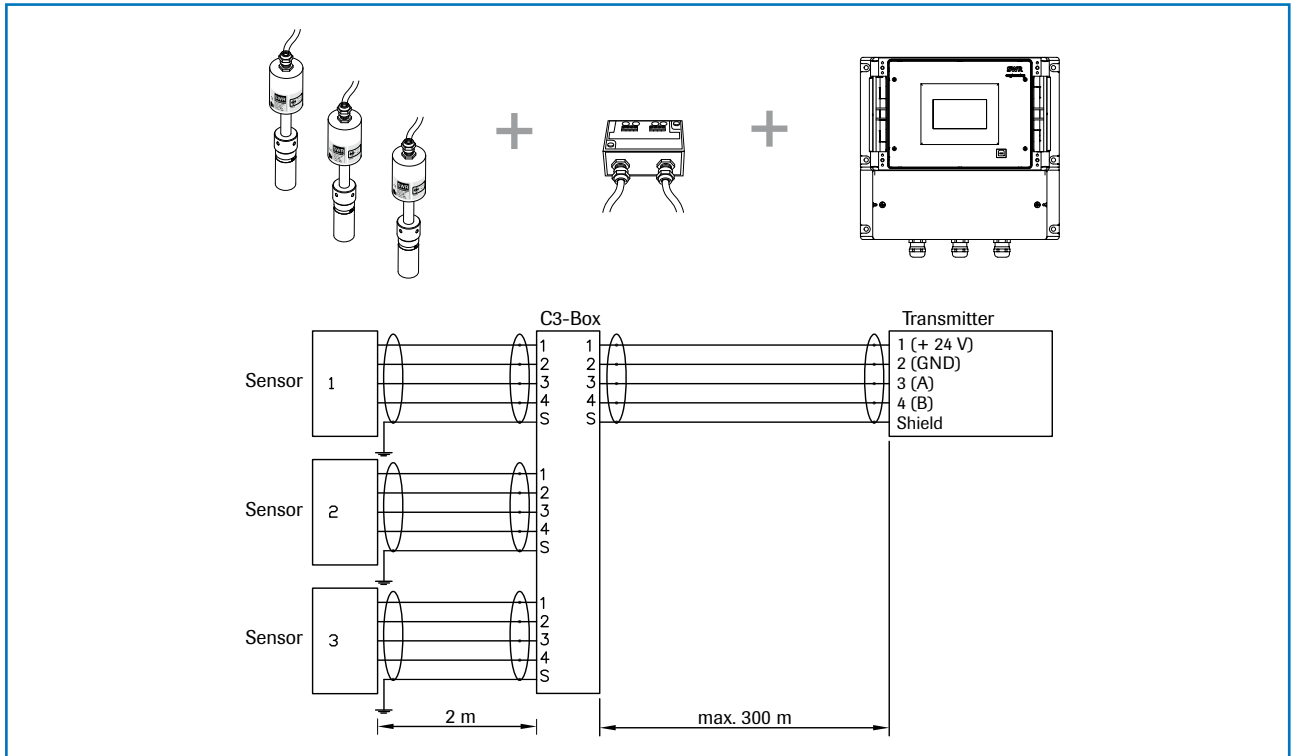

Fig. 3: Overview with C3-Box and field housing transmitter

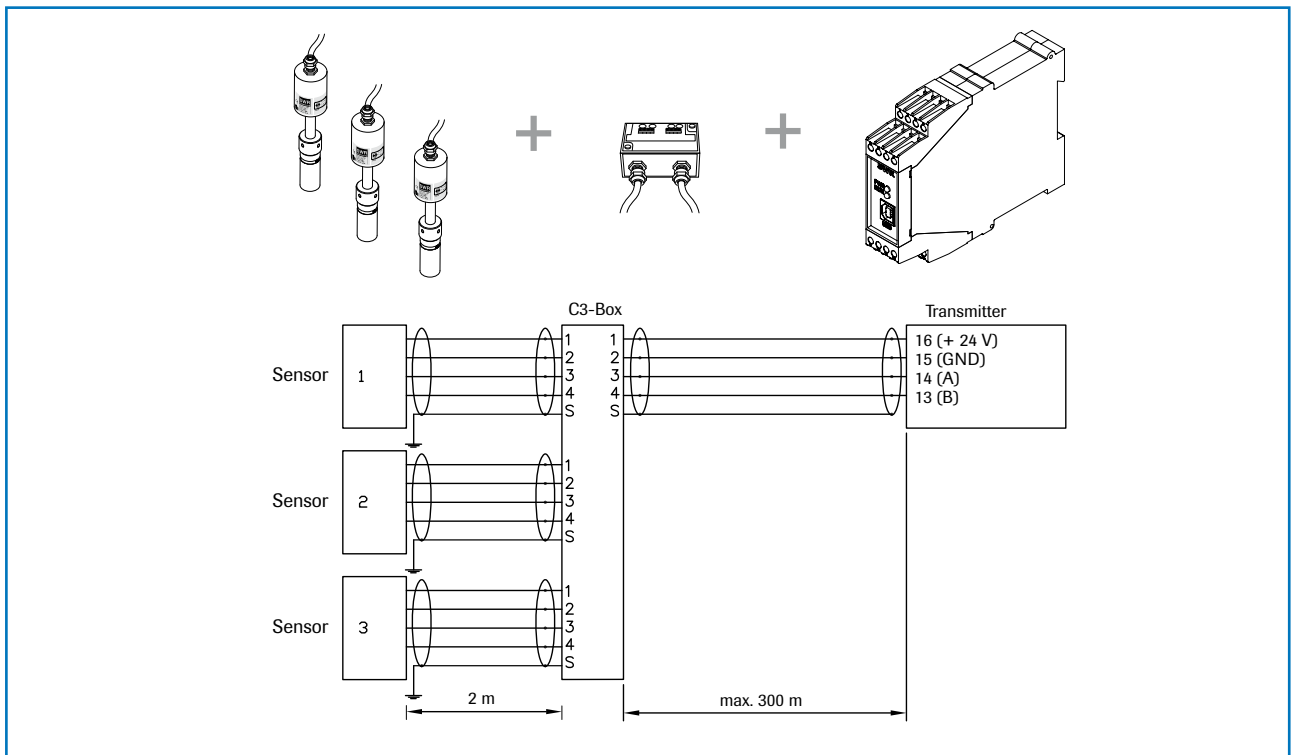

Fig. 4: Overview with C3-Box and DIN Rail transmitter

2. Function

- The SolidFlow 2.0 is a measuring system which has been specially developed for measuring the quantity of solids conveyed in pipelines.
- The sensor works with the latest microwave technology. It is only used in metallic pipelines. The special integration of microwave technology together with the metallic pipeline creates a homogeneous measurement field.
- The microwave radiation in the pipeline is reflected by the solid particles and received by the sensor. The frequency and amplitude of the received signals are analysed.
- The frequency-selected evaluation system ensures that only moving particles are measured and deposits are suppressed.
- SolidFlow 2.0 features active stratification compensation which increases measurement accuracy.

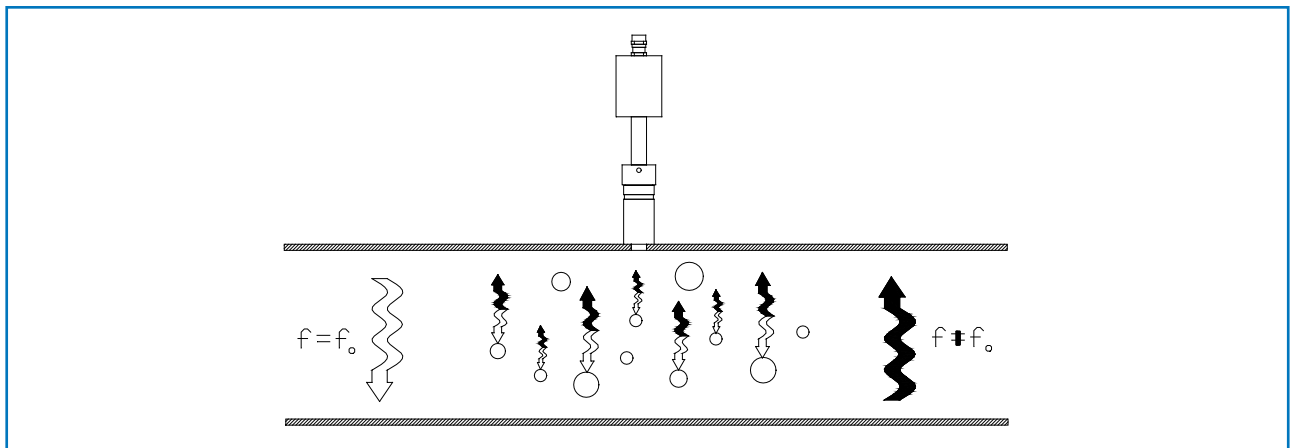

Fig. 5: Integration and reflection of microwaves

3. Safety

The SolidFlow 2.0 measuring system has a state of the art, reliable design. It was tested and found to be in a perfectly safe condition when leaving the factory. Nevertheless, the system components may present dangers to personnel and items if they are not operated correctly.

Therefore, the operating manual must be read in full and the safety instructions followed to the letter.

If the device is not used correctly for its intended purpose the manufacturer's liability and warranty will be void.

3.1 Normal use

- The measuring system may only be installed in metallic pipes to measure the medium passing through them.
It is not suitable for any other use or measuring system modifications.
- Only genuine spare parts and accessories from ENVEA - SWR engineering may be used.

3.2 Identification of hazards

- Possible dangers when using the measuring system are highlighted in the operating instructions with the following symbols:



Warning!

- This symbol is used in the operating manual to denote actions which, if not performed correctly may result in death or injury.



Attention!

- This symbol is used in the operating manual to denote actions which may result in danger to property.

3.3 Operational safety

- The measuring system may only be installed by trained, authorised personnel.
- During all maintenance, cleaning and inspection work on the pipelines or SolidFlow 2.0 components, make sure that the system is in an unpressurised state.
- Switch off the power supply before performing any maintenance work, cleaning work or inspections on the pipelines or the SolidFlow 2.0 components. See the instructions in the section entitled Maintenance and care.
- The sensor must be taken out of the pipeline before any welding work is performed.
- The components and electrical connections must be inspected for damage at regular intervals. If any signs of damage are found, they must be rectified before the devices are used again.

3.4 Technical statement

- The manufacturer reserves the right to adjust technical data concerning technical developments without notice. ENVEA - SWR engineering will be delighted to provide information about the current version of the operating manual, and any amendments made.

4. Mounting and installation

4.1 Typical components of the measurement point:

- Transmitter in the DIN Rail housing or field housing
- Sensor mount for welding to the pipeline
- Sensor (union nut, spacer rings, sealing ring for adjusting to the wall thickness)
- Installation instructions
- Teflon sleeve (depend on application)
- C1- or C3-Box (optional)

4.2 Required equipment

- Ø 20 mm twist drill bit
- 32 mm open-ended spanner for union nut
- Locking ring pliers (Ø 20 mm) to adjust the sensor to the wall thickness

4.3 Sensor installation

Proceed as follows to install the sensor:

- Decide on the installation position on the pipe. It should be installed from the top on horizontal or angled pipelines.
- From a pipe diameter of 200 mm, 2 sensors are used. The sensor must be mounted offset in relation to each other at an angle of 90°.
- From a pipe diameter of 300 mm, 3 sensors are used. The sensor must be mounted offset in relation to each other at an angle of 120°.

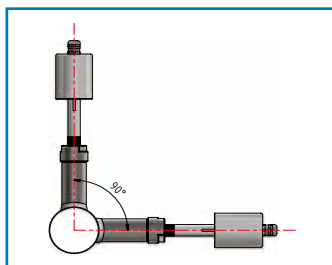

Fig. 6: 2 sensor with 90° offset

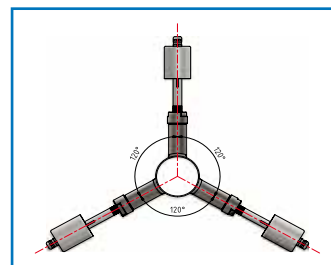

Fig. 7: 3 sensor with 120° offset

- The distances apply to vertical and horizontal installations.
- Ensure that the measurement point is at an adequate distance from valves, manifolds, blowers and bucket wheel feeders and other measurement ports such as those used for pressure and temperature sensors, etc. (see fig. 8)

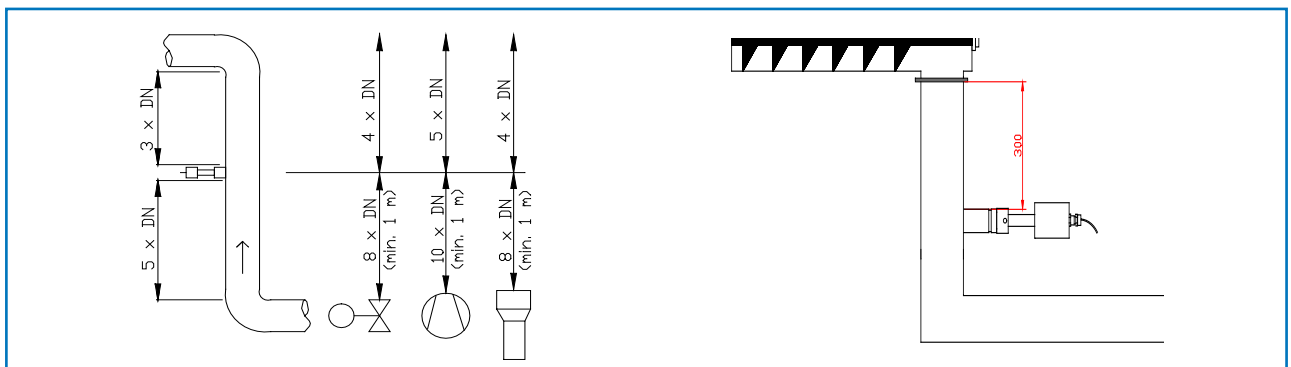

Fig. 8: Minimum distances of the measurement point from pipe geometries and fittings

- On free-fall applications (for example, after screw conveyors or bucket wheel feeders), a drop height of at least 300 mm is ideal.

- Weld the sensor mount to the pipe.
- Drill through the pipe through the sensor plug (Ø 20 mm). Ensure that the borehole is not angled so that the sensor can be installed precisely at a later stage.



Attention!

- After drilling, it is essential to check whether the drill bit has caused any burrs on the borehole edges. Any burrs on the pipe must be removed using a suitable tool. If the burrs are not removed they may affect the sensor's calibration.
- If the sensor is not installed immediately insert a plug until it is installed (see also fig. 9). The plug must be inserted together with the seal, two sealing rings and the locking ring, and secured using the union nut. Use a 32 mm open-ended spanner to tighten the union nut.

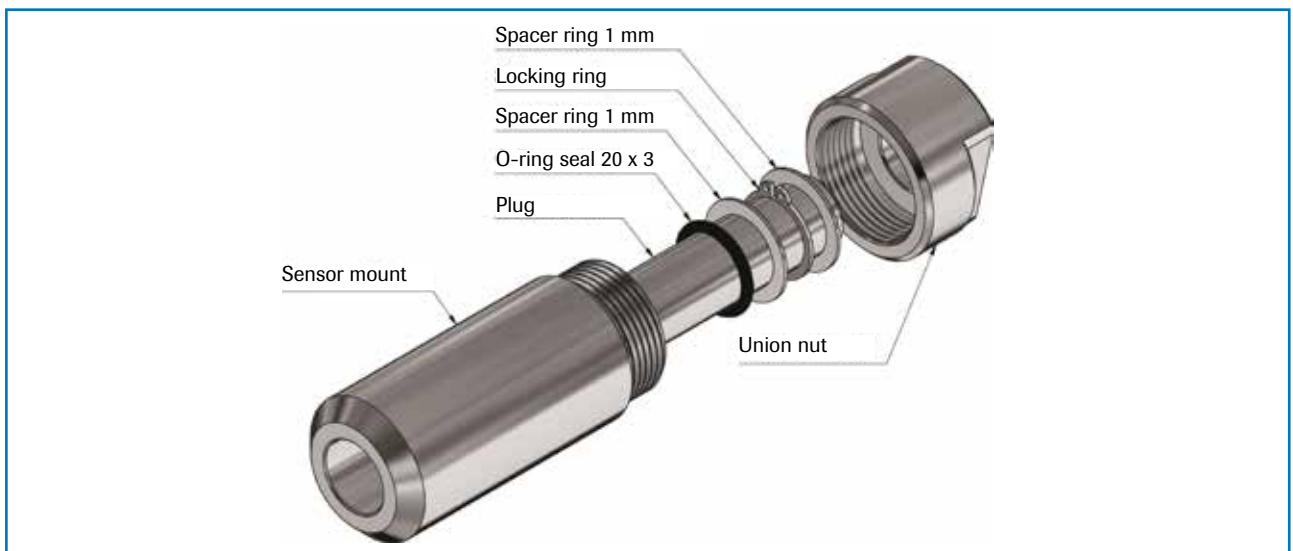

Fig. 9: Installation of the sealing plug in the sensor mount



Attention!

- Remove the sealing plug to insert the sensor.
- The sensor is supplied pre-assembled for the specified wall thickness or, if no wall thickness was specified, to a wall thickness of 4 mm. Check again that it is correctly adjusted before installation (see table). If necessary, the wall thickness must be remeasured using a depth gauge. The weld-on socket is 93 mm long. It is important that the sensor does not project into the pipe. The sensor may be up to 1 mm inside the pipe wall without this causing a measurement error.

Wall thickness (mm)	Position on the sensor neck	Number of spacer rings
3.0	1	2
4.0	1	1
5.5	2	2
6.5	2	1
8.0	3	2
9.0	3	1
10.5	4	2
11.5	4	1
13.0	5	2
14.0	5	1

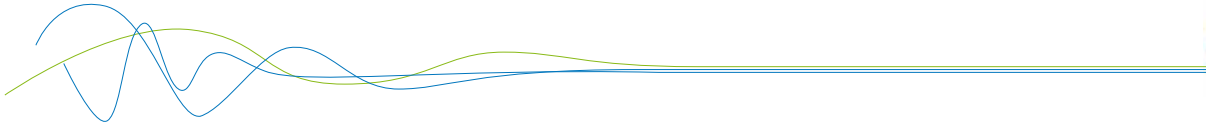

- Now insert the sensor into the sensor mount as shown in Figure 10.

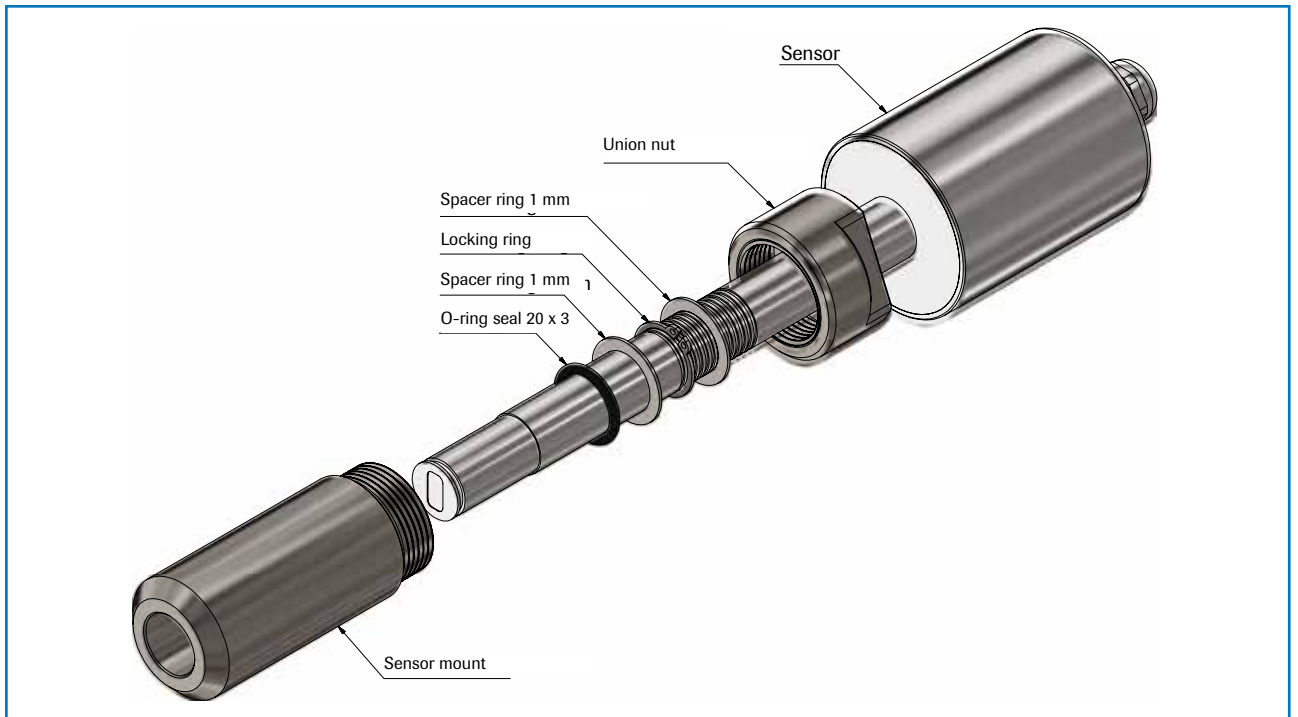

Fig. 10: Install the sensor mount and the sensor

- If a Teflon sleeve is required, the corresponding sensor mount must be drilled out with a 25 mm drill. After drilling, install the Teflon sleeve and sensor as shown in the following figure.

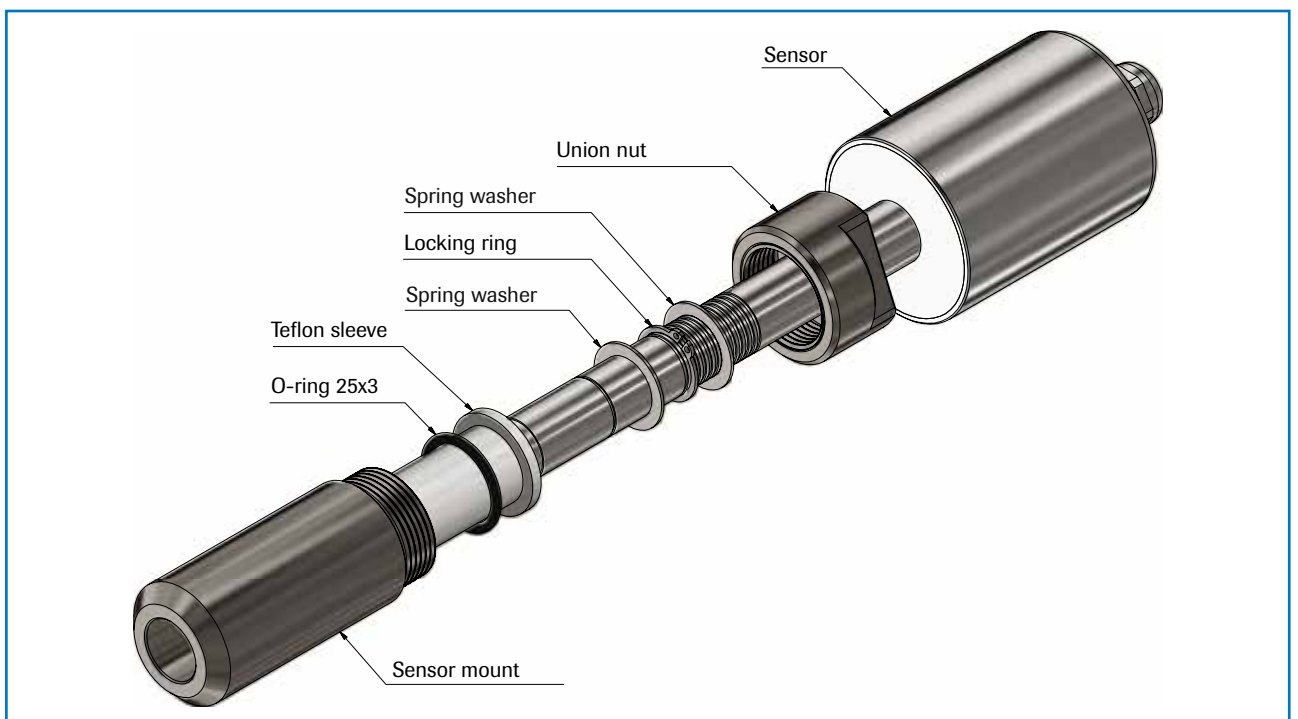
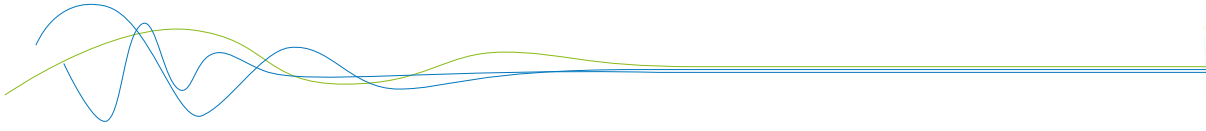

Fig. 11: Installation of sensor with Teflon sleeve



- and align it longitudinally to the pipe axis as shown on the polarisation sticker (Fig. 12). Then seal the measurement point with the union nut.

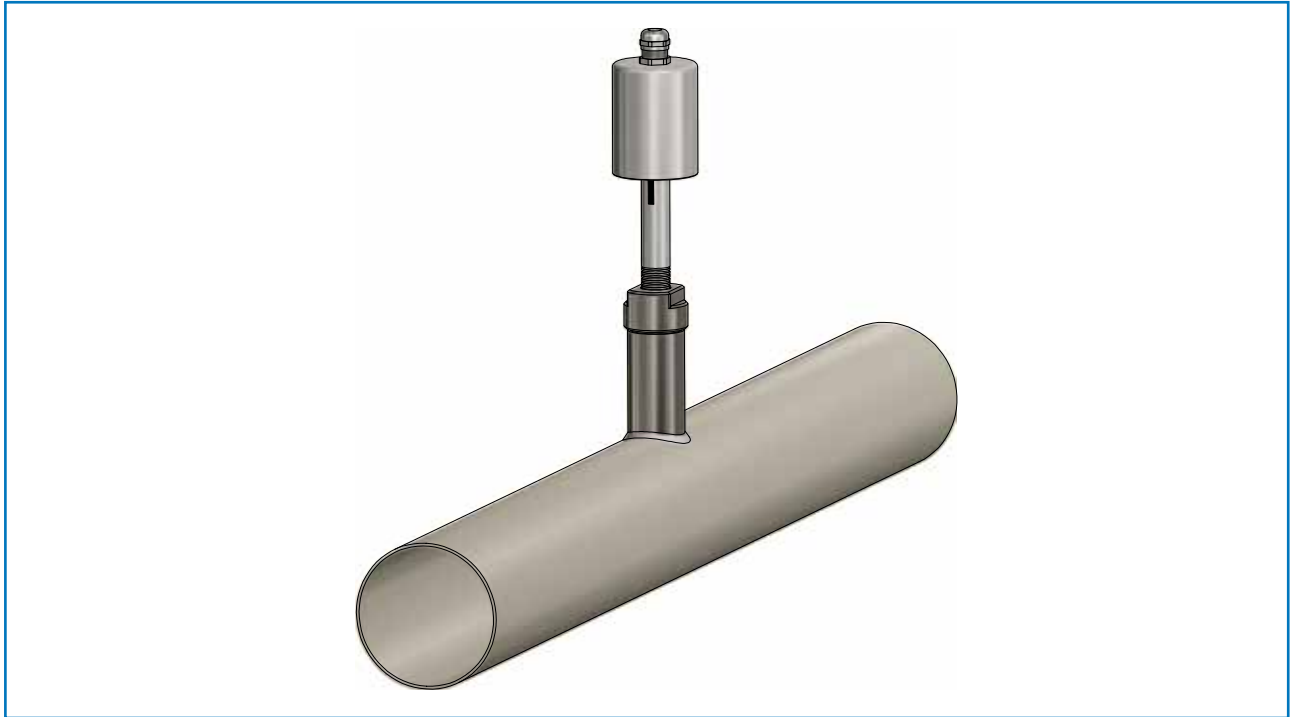
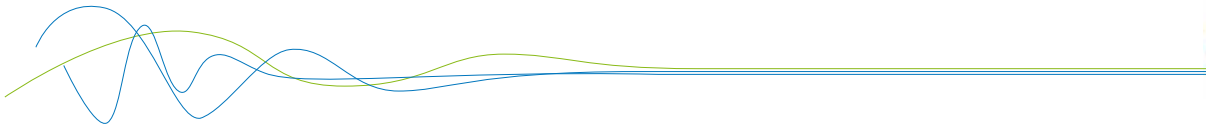

Fig. 12: Sensor alignment



4.4 Mounting the transmitter

The transmitter can be installed at a maximum distance of 300 m from the sensor. A cable of type “Öflex Classic 110 CY” is recommended. The cable should be four wired, twisted and shielded. A minimum cable cross-section of 0.75 mm² should be observed. For distances more than 150 m the cable cross-section should be adjusted.

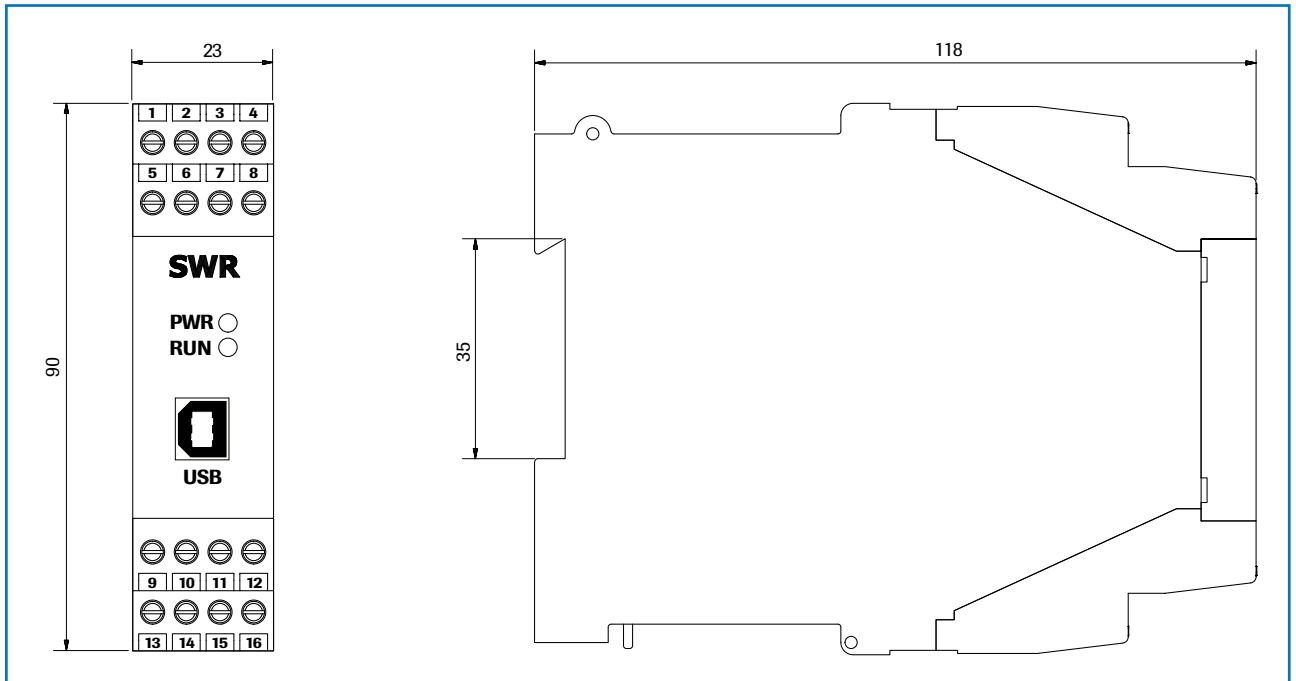

Fig. 13: Dimension DIN Rail housing for the transmitter

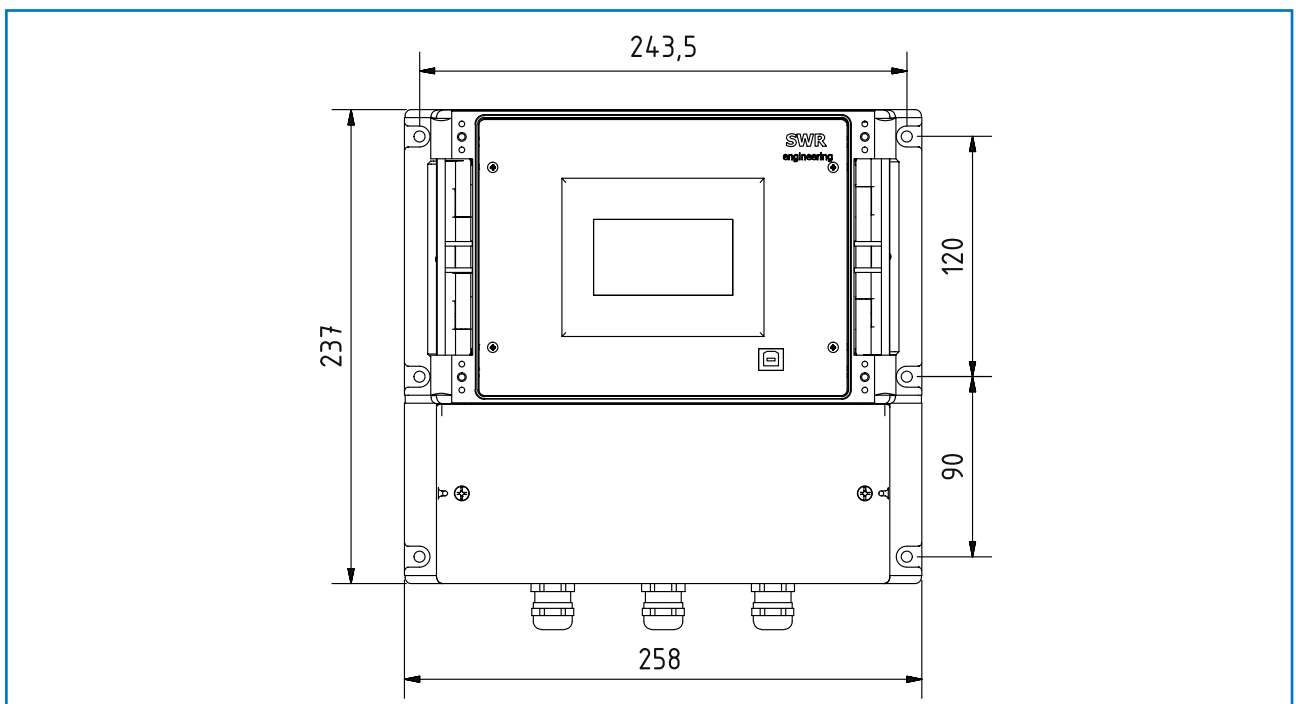

Fig. 14: Dimension field housing for the transmitter (front)

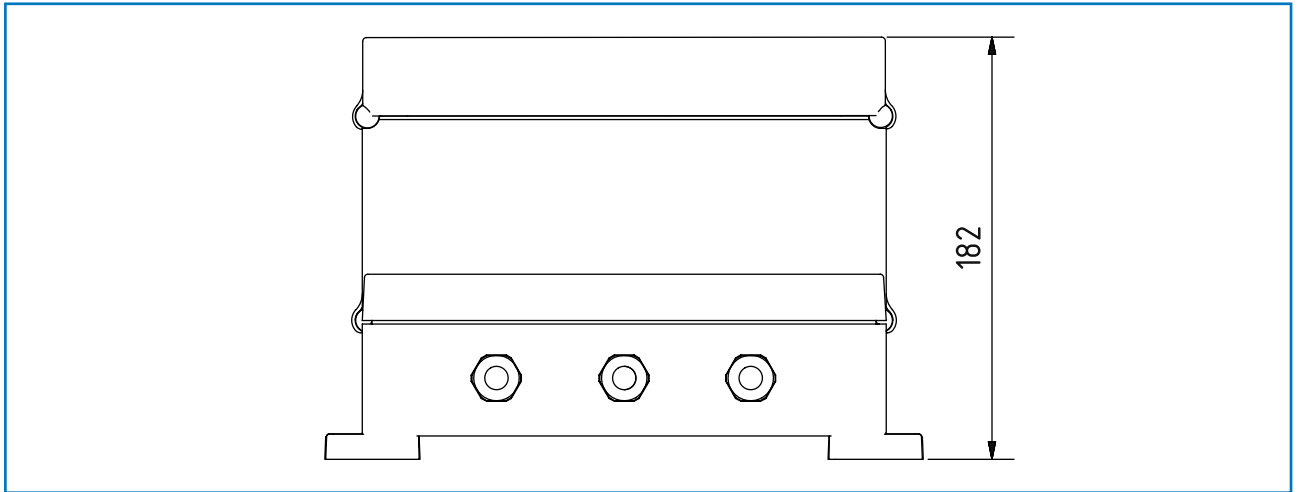
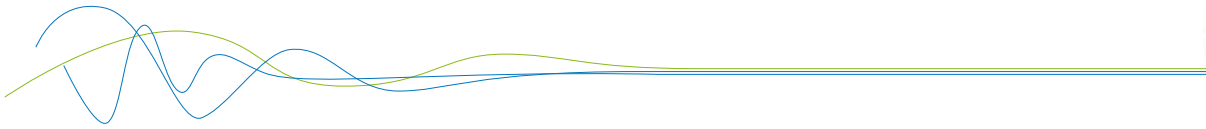

Fig. 15: Dimension field housing for the transmitter (side view)

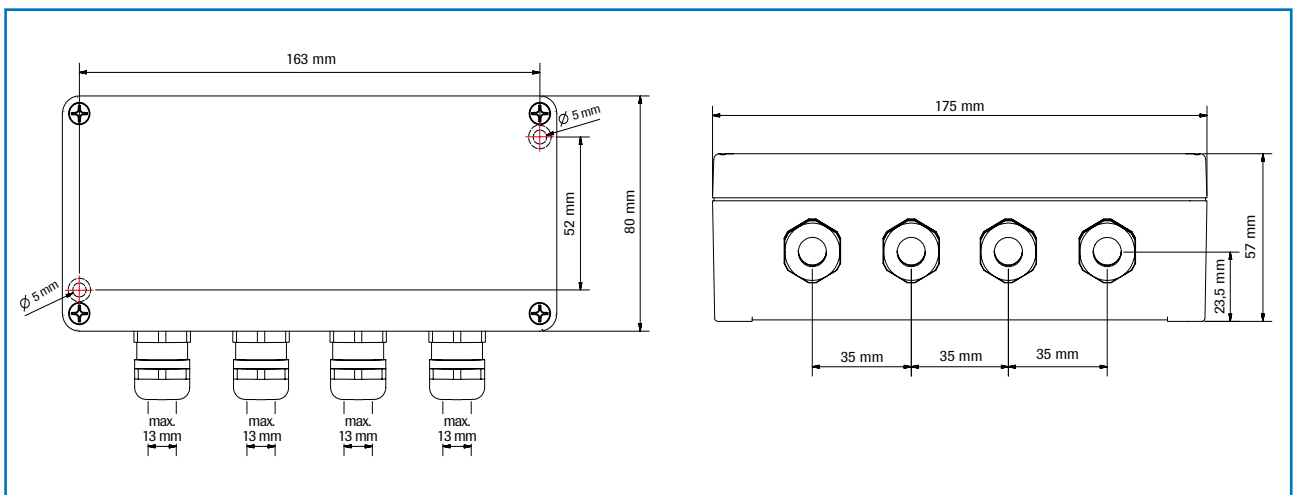

Fig. 16: Dimension field housing C3-Box

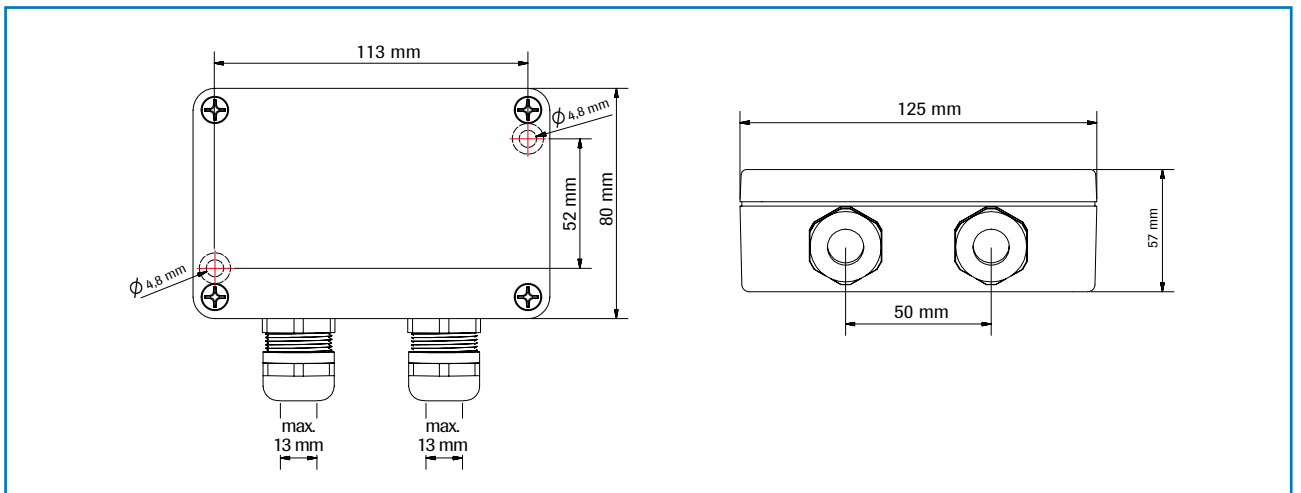

Fig. 17: Dimension field housing C1-Box

4.5 Use in hazardous areas

Dust explosion zone identification:

II 1/2D Ex tD IP 65 T84 °C

Zone 20: $0\text{ °C} \leq T_{\text{process}} \leq 80\text{ °C}$

Zone 21: $-10\text{ °C} \leq T_{\text{amb}} \leq 60\text{ °C}$

- Equipment group 2
- Equipment category: 1/2
Waveguide window zone 20 / housing zone 21
- For explosive mixtures of air and combustible dust
- IP code 65
- Maximum surface temperature 84 °C at $T_a = 60\text{ °C}$

Gas explosion zone identification:

II 1/2D Ex tD A20/21 IP 65 T84 °C

II 2G Ex d IIC T5/T3

- Equipment group 2
- Equipment category: 2
- Zone 1
- For explosive mixtures of air and combustible gases
- IP code 65
- Permitted process temperature 0 to 150 °C
- Temperature class T3
- Maximum surface temperature 84 °C at $T_a = 60\text{ °C}$

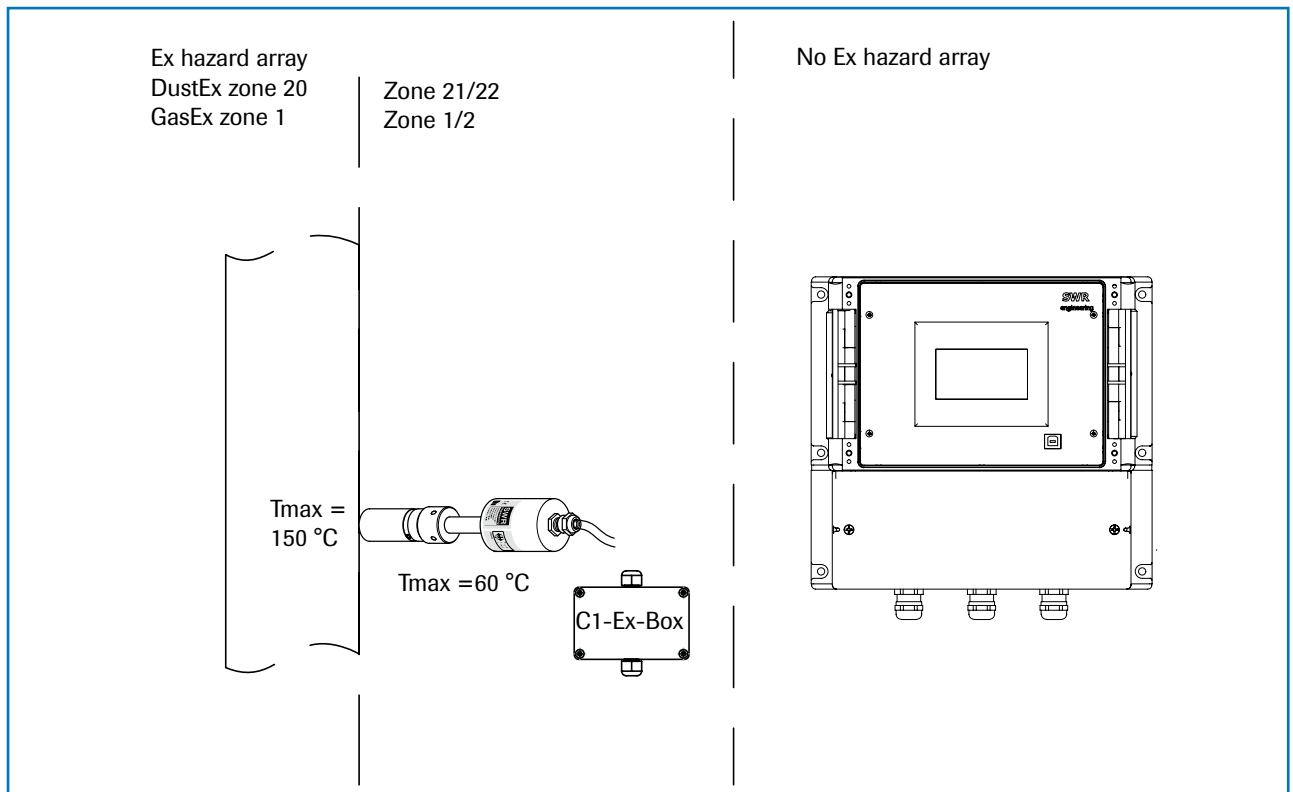

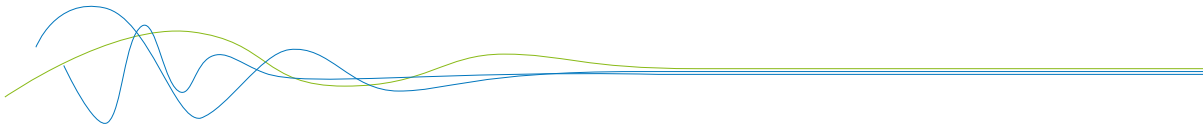

5. Electrical connection

5.1 DIN Rail terminal layout

1 Current output - 4 ... 20 mA	2 Current output + 4 ... 20 mA	3 Input Power supply 0 V DC	4 Input Power supply + 24 V DC
5 Not used	6 Alarm relay NC (break contact)	7 Alarm relay C	8 Alarm relay NO (make contact)

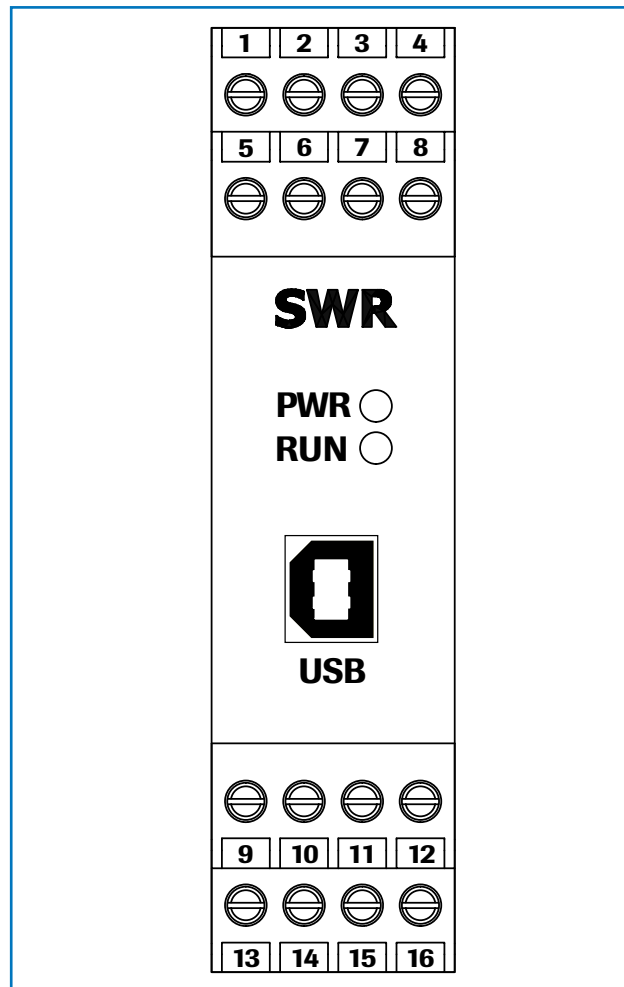
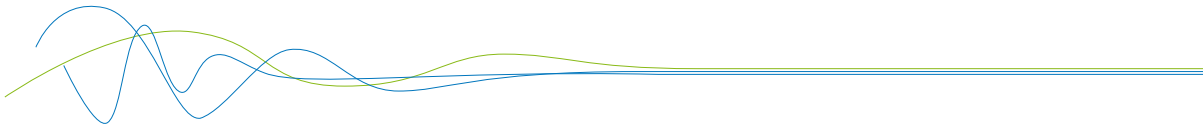

Fig. 19: Electrical connection of the transmitter

9 Digital pulse output (-)	10 Digital pulse output (+)	11 RS 485 Interface Data B	12 RS 485 Interface Data A
13 Sensor connection Cable 4 RS 485 Data B	14 Sensor connection Cable 3 RS 485 Data A	15 Sensor connection Cable 2 Power supply 0 V	16 Sensor connection Cable 1 Power supply + 24 V



5.2 Field housing terminal layout

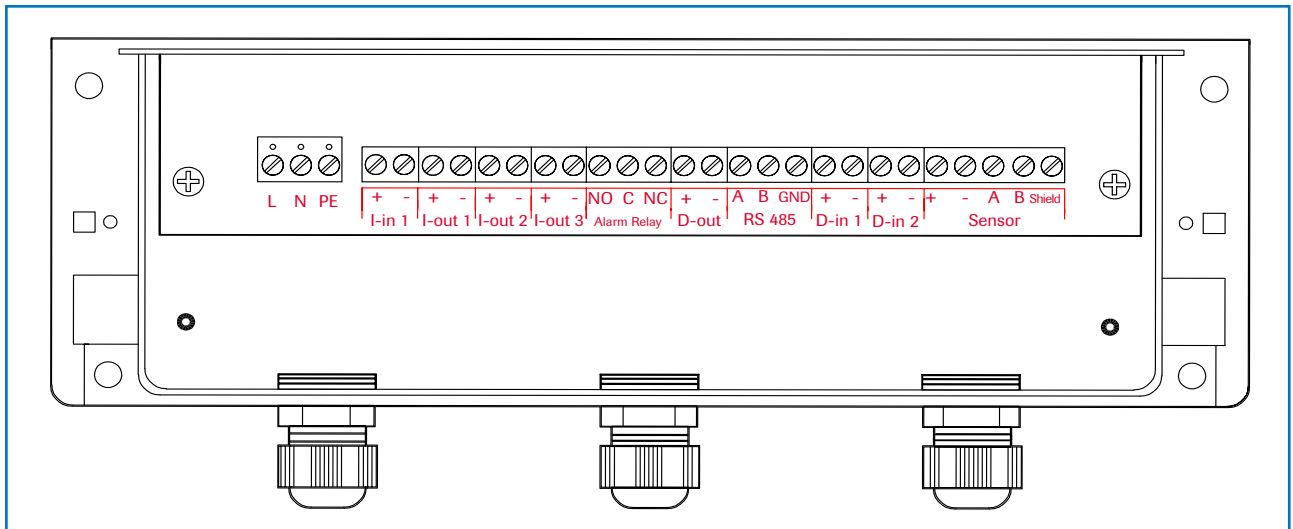
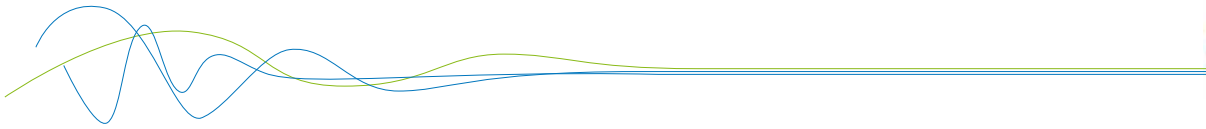

Fig. 20: Electrical connection

Transmitter			
Terminal no.	Connection		
Power supply connection			
L / +24 V	Input power supply 230 V / 50 Hz, 110 V / 60 Hz (optional 24 V DC)		
N / 0 V	Input power supply 230 V / 50 Hz, 110 V / 60 Hz (optional 24 V DC)		
PE	Earth		
Connections			
I-in1	+	Current input +	
	-	Current input -	
I-out1	+	Current output +	
	-	Current output -	
	Na	Not used	
	Na	Not used	
	Na	Not used	
	Na	Not used	
Min. / Max.-Relay	NO	Floating change-over contact NO (make contact)	
	C	Floating change-over contact C (common conductor)	
	NC	Floating change-over contact NC (break contact)	
D-out	+	Digital pulse output +	
	-	Digital pulse output -	
RS 485	A	RS 485 interface data A	
	B	RS 485 interface data B	
	GND	RS 485 interface ground	
D-in1	+	Digital interface 1 (+)	
	-	Digital interface 1 (-)	
D-in2	+	Digital interface 2 (+)	
	-	Digital interface 2 (-)	
Sensor	+	Power supply + 24 V	Cable no. 1
	GND	Power supply 0 V	Cable no. 2
	A	RS 485 data A	Cable no. 3
	B	RS 485 data B	Cable no. 4
	Shield	Shield	



5.3 Electrical connection C-Box

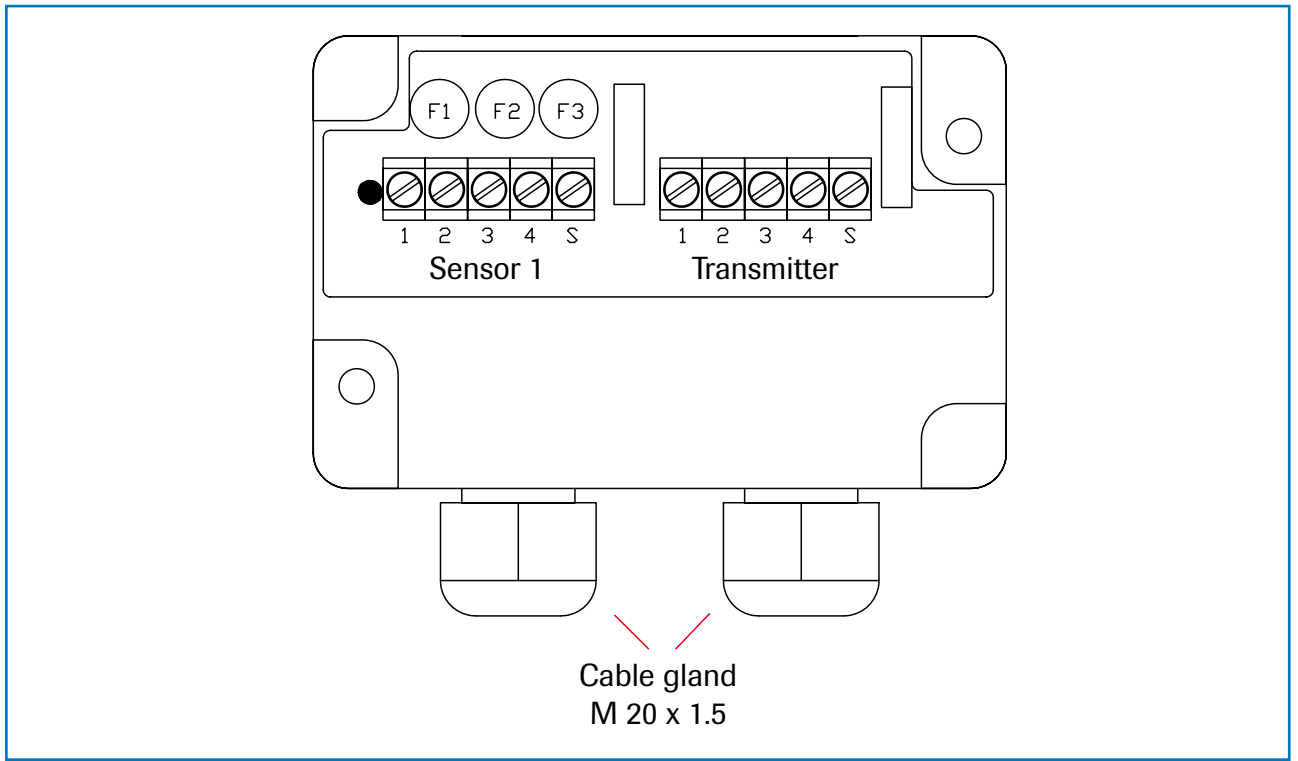

Fig. 21: Electrical connection C1-Box

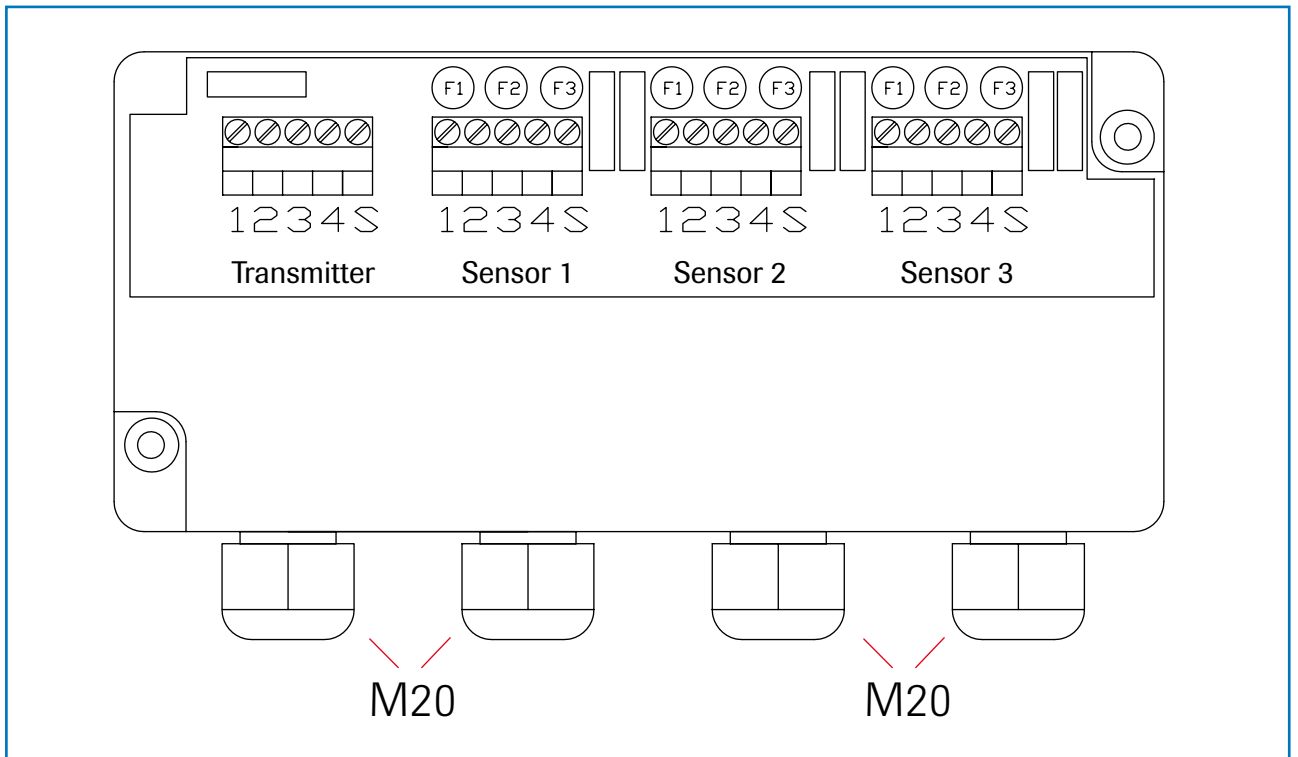
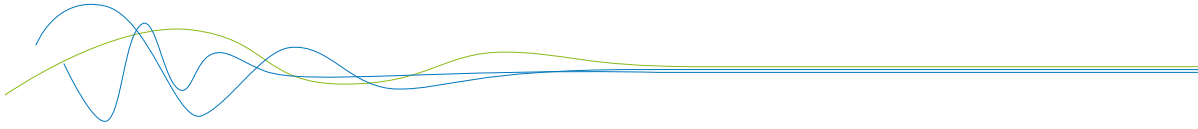

Fig. 22: Electrical connection C3-Box



6. Operator interface

The transmitter is a multi-sensor transmitter. It is therefore strongly recommended to check before commissioning whether the correct sensor is selected in menu **System**.

The operator interface differs depending on the system design:

- DIN Rail housing without touchscreen, operation via PC software
- Field housing with display, alternative operation via PC software
- One to three sensor system

First of all, the different system versions are described below. Following that, the basic operation of the SolidFlow 2.0 system as a one sensor system is then described without going back over the different versions.

6.1 Differences between the DIN Rail and field housing transmitter

The transmitter in the DIN Rail housing is only a part of the functions available in the field housing. The following overview clarifies the differences between the two versions.

Function	Field housing	DIN Rail
Menu system		
• via PC software	yes	yes
• via display	yes	no
Measurement value display current output	yes	yes
Pulse output for the control of solenoid valves or for totaliser output	yes	yes
Alarm system relay output	yes	yes
Remote control digital input	yes	no
Autocorrect analogue input	yes	no
Totaliser display		
• via PC software	yes	yes
• via display	yes	no
Error output		
• on current output	yes	yes
• at relay	yes	yes
• via PC software	yes	yes
• via display	yes	no
• on status LED	no	yes

The transmitter in the DIN Rail is configured exclusively via a USB connection and a PC program. For the transmitter in the field housing, all functions can be configured via the touch-sensitive display. The PC configuration is also possible with the transmitter in the field housing.

The menu items on the display and in the PC software are numbered in a uniform manner so that they can be referred to later on.

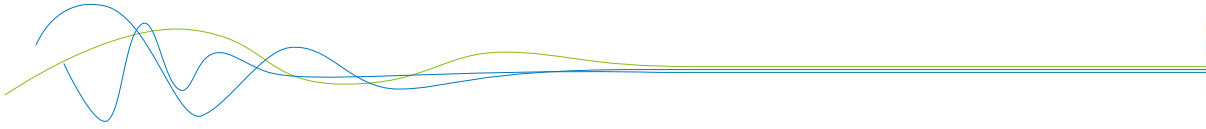

6.2 Display

The display is touch-sensitive. Available keys are displayed directly in context. When the measuring system is first started, a query is initiated to select the language and sensor. If no selection is made, the initialization disappears and the German language with a SolidFlow 2.0 sensor is selected.

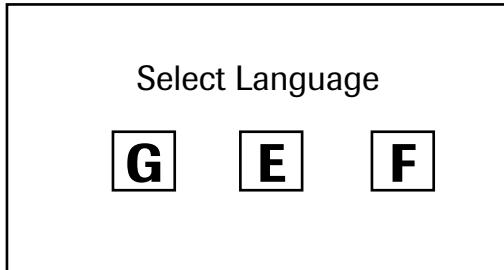

Initialization screen when the transmitter in the field housing started first time.

Selection of the menu language:

German, **E**nglish, **F**rench

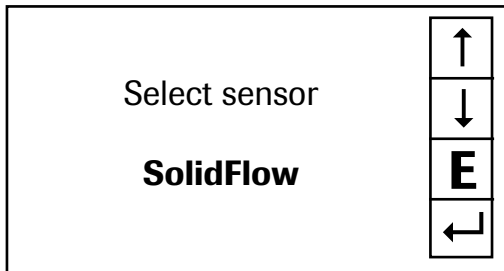

If a language has been selected, the sensor to be used must be selected.

To be available:

SolidFlow 2.0, PADDY, PicoFlow, MaxxFLOW HTC, DensFlow, SpeedFlow 2.0, SlideControl, ProSens, M-Sens FD, M-Sens 2, M-Sens WR.

Afterwards the start page appears.

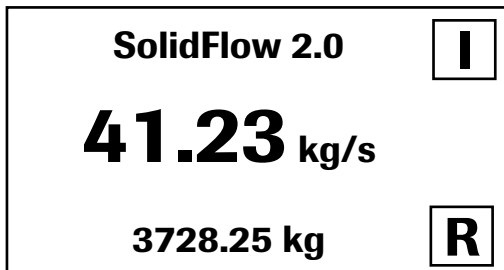

The start page display the following values:

- Tag No "SolidFlow 2.0", freely selectable text which describes the material or the measuring point
- Measurement, here in [kg/s]
- Totaliser value since the last totaliser reset, here in [kg]
- [I] key for info
- [R] key for totaliser reset

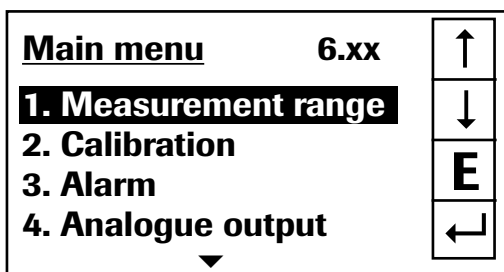

To access the menus, press and hold any area of the display for several seconds.

The sub-menu selection will be displayed:

In the menus and input fields, the displayed keys can be used to browse, select, edit or reject:

- Arrow: Scroll down the page, Select an option, Select a position in the input text
- [E] for ESC: Interrupt the function without making any changes
- [↵]: Select the function or confirm the input
- [C] for Clear: Delete a symbol or number.

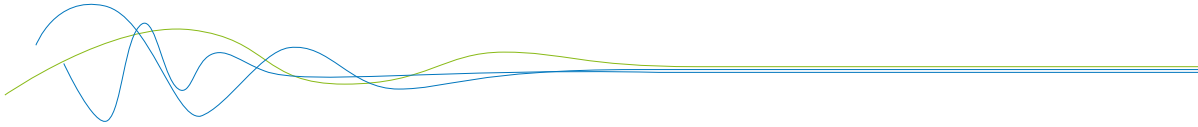

Sensor status			
	Temp	Raw value	Stat
S1	63.0	0.000123	OK
S2	63.0	0.000213	OK
S3	63.0	0.000321	OK
Average value	0.000219		
	3728.25 kg		

With the key [I] you can choose between different information windows. The first window shows the raw values, temperature and the status of the sensor.

The second window displays the error memory.

Recent error codes always come first. If an error code is repeated, it will appear first, but will not be listed multiple times.

Save changes?	
<input type="checkbox"/> Y	<input type="checkbox"/> N

If any data has been changed, the change will only be taken into account when you exit the complete menu structure and answer [Yes] when asked if you wish to save the changes.

For reasons of simplicity, a further display menu screen has been dispensed with. The display screens are directly derived from the menu structure in section 6.5.

Protection against unauthorised use:

If a password has been entered in menu **8. System** in **8.6 Password**, which is different to the "0000" default setting, you will be asked to enter a password when attempting to access the menus.

After the password has been successfully entered, the menus will be unlocked for approx. 5 minutes (from the last menu entry).

6.3 PC interface

Communication with a laptop or PC is carried out on the DIN Rail as in the field housing version optionally on the terminals via an RS 485 or on the front side via a USB interface.

- ✓ The **RS 485 connection** is attached to the transmitter in the field housing at the ModBus A (+) and ModBus B (-) terminals On the DIN Rail version, these connections are nos. 12 and 11, accordingly.
RS 485 is a bus connection; the ModBus address and the baud rate can be set on the device. Upon delivery, the communication parameters are set to:

- ModBus address 1
- Baud rate 9600, 8, E,1

An RS 485 to USB adapter can be purchased from envea™ - SWR engineering.

- ✓ For the USB connection to the DIN Rail version is a standard USB-A-B cable included.
The USB connection is a point-to-point connection that is not BUS-capable. The ModBus address and the baud rate for the front-side connections cannot be changed and are always:

- ModBus address 1 (or the device answers to all addresses)
- Baud rate 9600, 8, E,1

When connected to the PC for the first time, any interface drivers enclosed with the transmitter must be installed.

After starting the software, the communication parameters must first be entered accordingly. These can be found in the top left of the program window. The COM port to be set is displayed in the device manager.

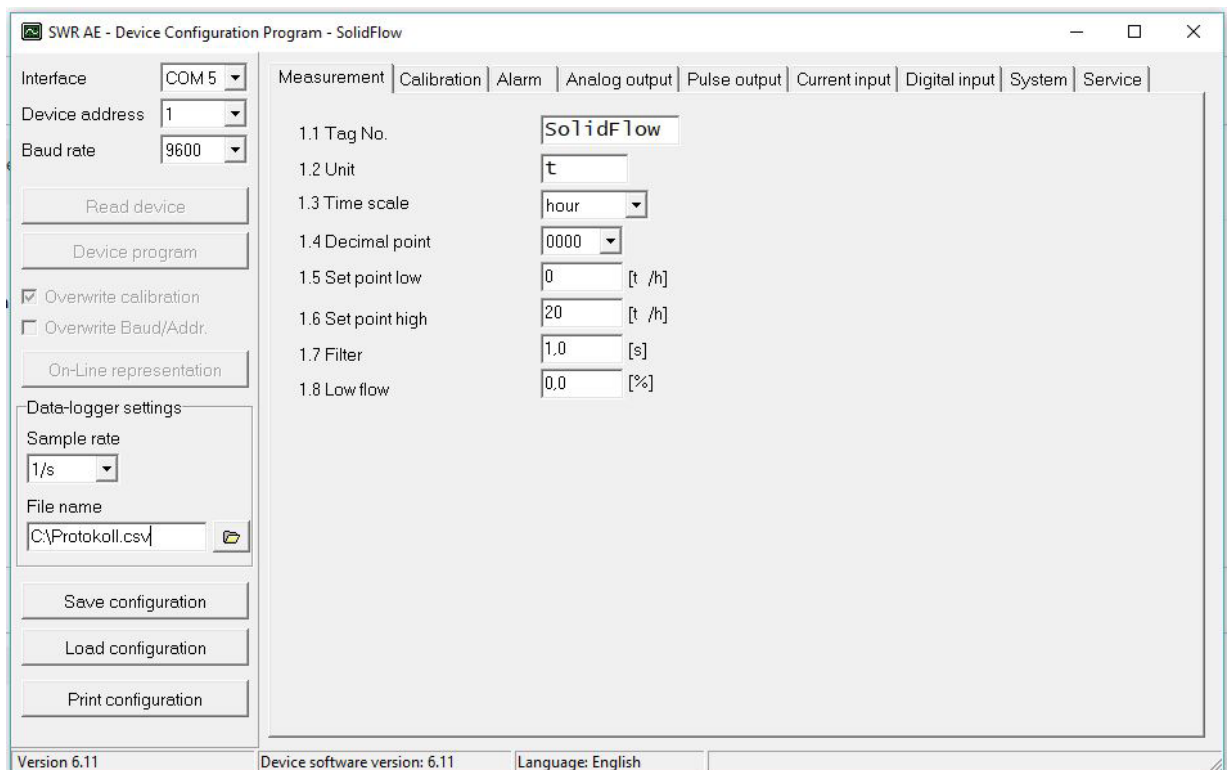

The screenshot shows the 'SWR AE - Device Configuration Program - SolidFlow' window. The 'Measurement' tab is active, displaying the following settings:

1.1 Tag No.	SolidFlow
1.2 Unit	t
1.3 Time scale	hour
1.4 Decimal point	0000
1.5 Set point low	0 [t /h]
1.6 Set point high	20 [t /h]
1.7 Filter	1.0 [s]
1.8 Low flow	0.0 [%]

On the left side, the 'Interface' is set to 'COM 5', 'Device address' is '1', and 'Baud rate' is '9600'. There are buttons for 'Read device', 'Device program', 'On-Line representation', 'Save configuration', 'Load configuration', and 'Print configuration'. The 'Data-logger settings' section shows a 'Sample rate' of '1/s' and a 'File name' of 'C:\Protokoll.csv'. The status bar at the bottom indicates 'Version 6.11', 'Device software version: 6.11', and 'Language: English'.

Communication is established by clicking on “Read device”. The acknowledgement message “Parameter read in” is displayed. If an error message is displayed instead, check the communication parameters and cable connections between the PC and the transmitter.

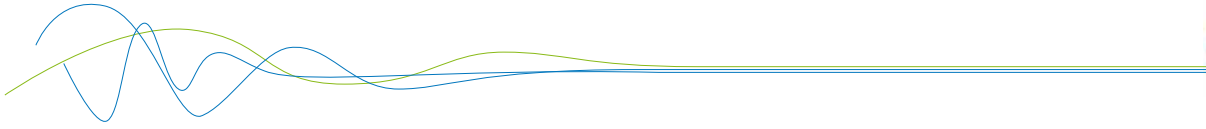

The edited data is transmitted to the transmitter via “Device program”.

Critical data concerning the ModBus communication and the calibration must be confirmed before the parameters are transmitted to the transmitter:

- ✓ If, when saving the the parameters in the transmitter, the system calibration data is changed, this action must be confirmed by checking “Overwrite calibration”.
- ✓ If, when saving the the parameters in the transmitter, the system interface parameters are changed, this must be confirmed by checking the selection “Overwrite baud/addr.”.

In addition, with the PC software,

- the transmitter parameters can be saved in a file (save configuration)
- the transmitter parameters can be loaded from a file (load configuration)
- the transmitter parameter can be printed via the windows standard printer (print configuration)
- the measured values can be logged in a data logger file (enter the file name and storage rate, and activate the data logger on the online display)

The software language can be set by right-clicking the “Sprache/Language/Langue” field in the bottom program line on “German/English/French”.

Protection against unauthorised use:

The PC interface does not have a password prompt as it is assumed that only authorised personnel will have access to the PC and the software. However, the password to operate the display can be read and changed in menu **8. System** in **8.6 Password**.

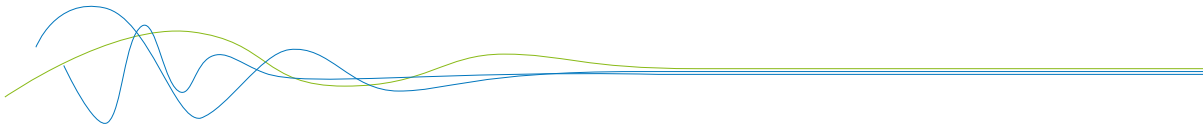

6.4 One or more sensor system

Up to three sensors can be connected to a transmitter if, for example, a larger flow section needs to be illuminated. In the transmitter, the corresponding number of sensors will then be registered and a joint average value will be calculated from their measurements.

The sensors are registered in menu **8. System**:

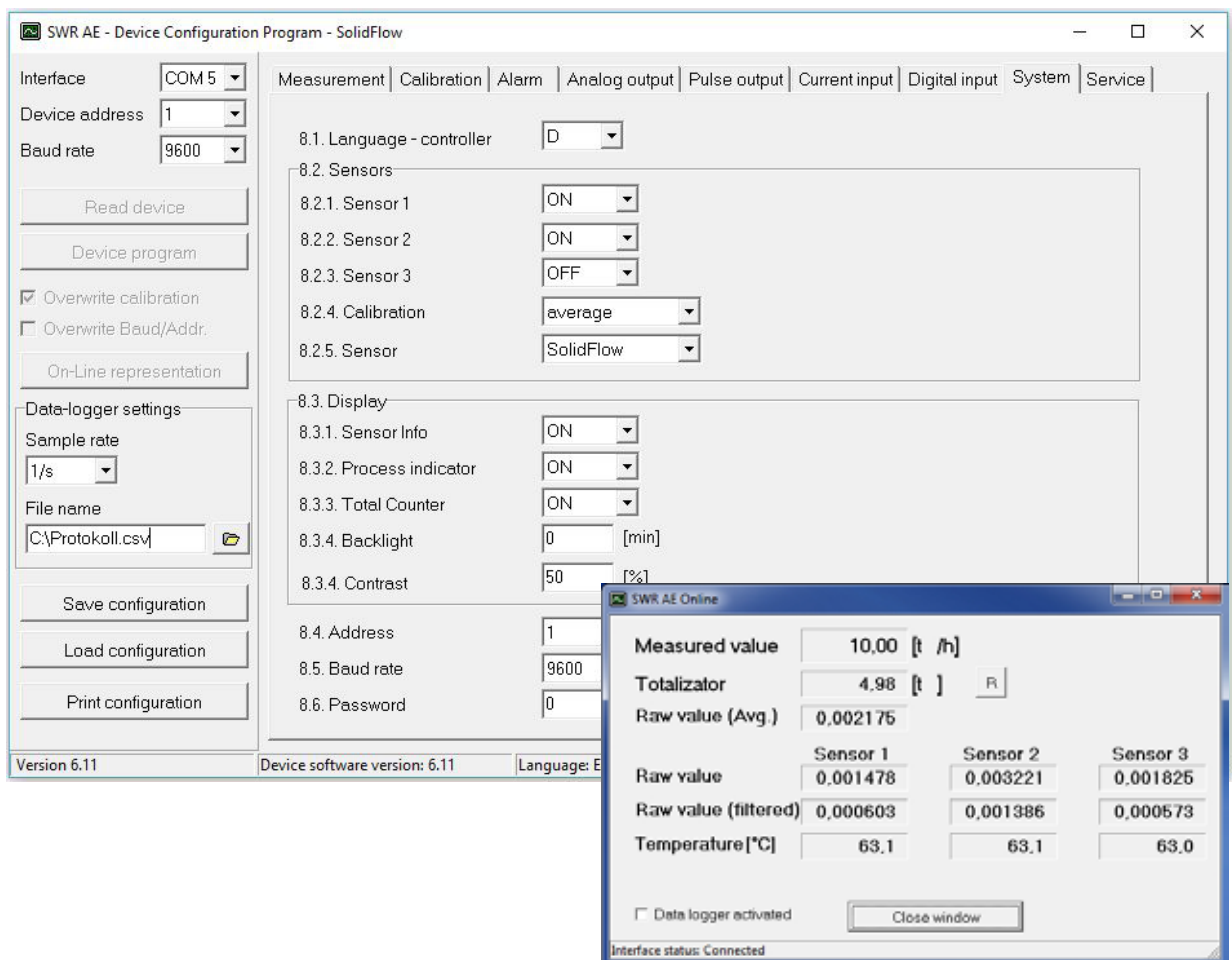

The multi-sensor function has no effect on the service and will not be explained in the following document.

If multiple sensors are used, this will only affect the application of sensors and the monitoring of sensors by the transmitter.

The presence of multiple sensors makes itself felt on the online-display and on the info area of the display.

For the construction of a multi-sensor system note the following:

- The sensors have to be activated in the transmitter (Menu **8. System, 8.2 Sensors**).
- Activated sensors are addressed by the transmitter on the sensor side, digital bus at the following addresses:
 - Address 1 – sensor 1
 - Address 2 – sensor 2
 - Address 3 – sensor 3

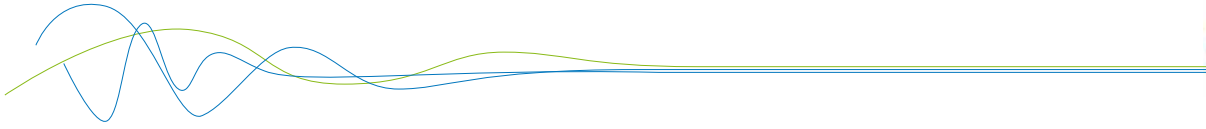

- With delivery of a multi-sensor system the sensors will be preconfigured on the addresses 1 – 2 – 3 and noted in the transmitter as active.
- Sensors and transmitters, which are not preconfigured for a multi-sensor system always have address 1, only sensor 1 will be activated.
- Sensors which are inserted afterwards in a system must be adjusted by means of an separate service software to the required address.
- The correct address will be factory-preset when ordering spare parts with specified sensor number.

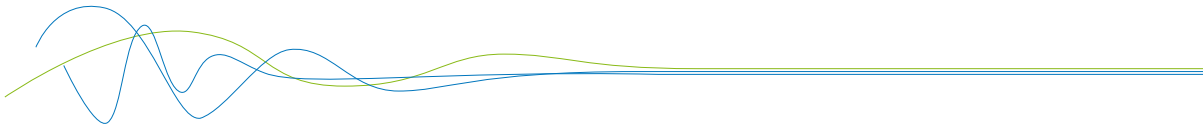

6.5 Menu structure

The menu structure supports the user when adjusting the measuring range, the calibration, the measurement values and the choice of additional functions. In this connection, the numbering both on the display and in the PC interface is identical:

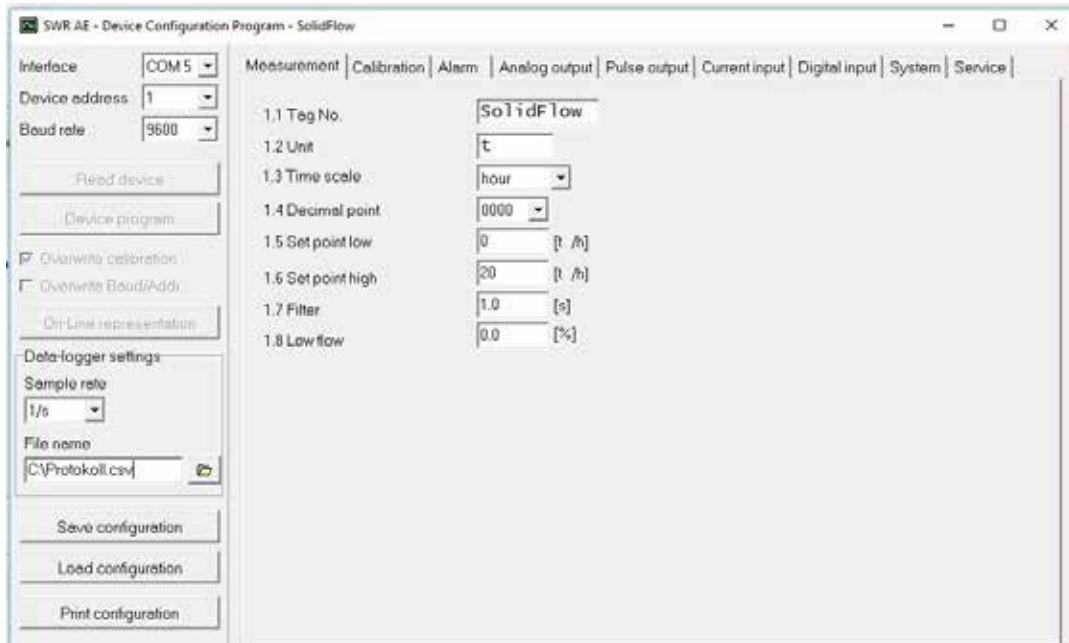

1. Measurement

Set all relevant measuring range settings

1.1 Tag No.	Input: Free text (10 characters)	Name of the measurement point or product.
1.2 Unit	Input: Unit text, e. g. kg	Required mass flow unit.
1.3 Time scale	Selection: hour / minute / second	time base for the integration by the totaliser and the pulse output.
1.4 Decimal point	Selection: 0000, 0.000, 00.00, 000.0	Number representation and decimal point-accuracy in the measurement menu.
1.5 Set point low	Input: 0 ... 9999	Throughput rates under this value will not be displayed at the current output. This does not concern the display indicator, totaliser or pulse output.
1.6 Set point high	Input: 0 ... 9999	Throughput rates above this value will not be displayed at the current output. This does not concern the display indicator, totaliser or pulse output.
1.7 Filter	Input: 0.0 s ... 999.9 s	Filtering of measurement for the indicator and the output values.
1.8 Low flow	Input: 0.0 % ... 99.9 %	Throughput below this threshold are displayed as zero and are NOT totalised. Indication as % to measuring range end.

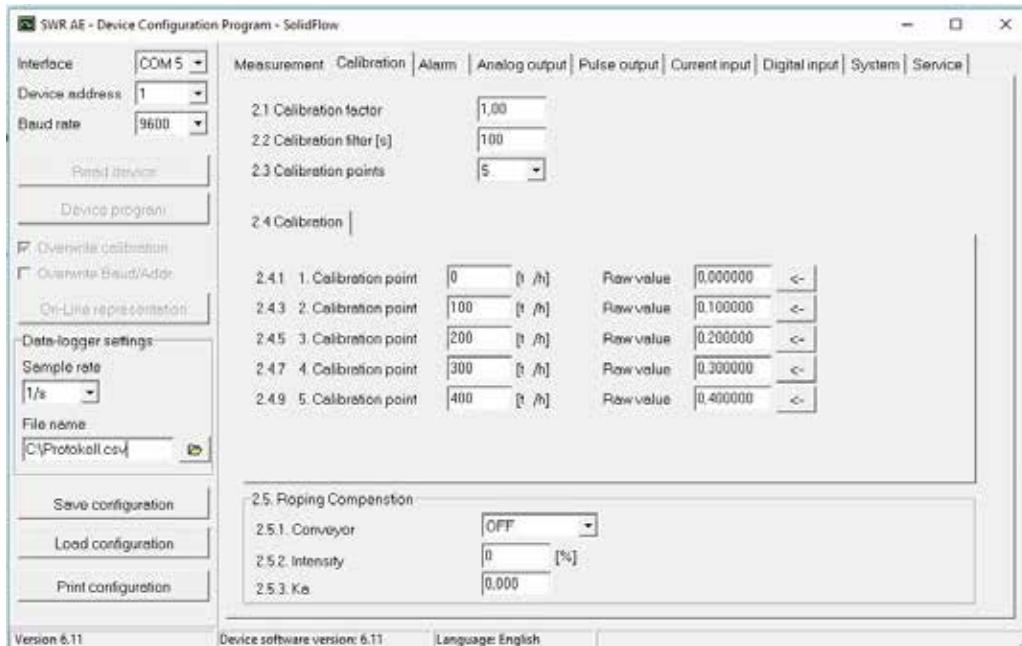
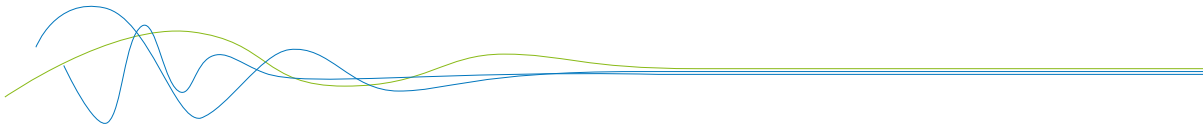

2. Calibration

Deposit a calibration curve

- | | | | |
|-------|---|---|---|
| 2.1 | Calibration factor | input: 0.01 ... 9.99 | Factor for the subsequent adjustment of the actual measurement. All measurements are measured with this factor. |
| 2.2 | Calibration filter [s] | Input: 1 s ... 9999 s | Filter time for recording the raw value during calibration. It would be made an average out of the measured RAW-values. |
| 2.3 | Calibration points | Input: 2 ... 5 | Number of support points for a linearisation above the operating range. |
| 2.4 | Calibration | Calibration sub-menu | |
| 2.4.1 | P1 value | Input: Measurement | Output measurement in the selected mass/time unit. |
| 2.4.2 | P1 calibration | Transfer: Raw value | Transfer of the current raw value (filtered) from the mass flow with the key [←]. The value can also be entered directly. |
| | ... (depending on the number of support points) | | For additional support points (depending on [2.3]), additional value pairs can be set. |
| 2.4.n | Pn value | Input: Measurement to be displayed | |
| 2.4.n | Pn calibration | Transfer: Current raw value | |

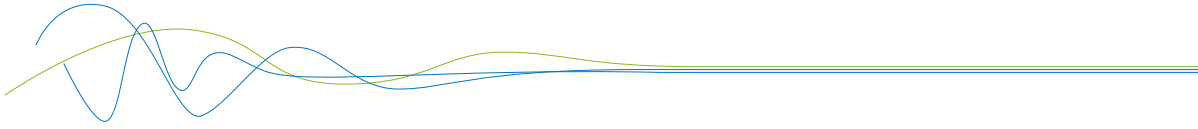

2.5 Roping compensation **Roping compensation sub-menu**

The stratification compensation is used to compensate for measurement uncertainties which can arise due to stratification. The sensors are supplied with an optimum default setting for normal conveying conditions. If the measurement is influenced by unusual flow stratifications or stratification shifts, the intensity of the compensation can be increased from 0 % to up to 100 %.

The sensor has two parameter sets for gravimetric and pneumatic conveying conditions. They should be selected depending on the type of conveyance. The intensity adds part of the compensated measurement to the uncompensated measurement: Both parts are weighted and calculated according to the selected intensity.

When using this function, it is recommended to set first the intensity to 100 % and activate the compensation. Subsequently, the Ka has to be adapted such that the raw value with 100 % compensation is on the same range as the raw value without compensation.

If the Ka is adjusted correctly, the intensity should be reset and increased in steps of 10 % to assess the quality of the measurement results.

A manual parameter set can be set and permanently stored by trained ENVEA - SWR engineering personnel.

2.5.1	Conveyor	Selection: OFF / GRV / PNE / MAN	OFF: no compensation GRV: gravimetric conveyance = free fall PNE: Pneumatic conveyance MAN: Manual parametrisation (only for trained ENVEA - SWR engineering personnel)
2.5.2	Intensity	Input: 1 ... 100 %	Strength of calculation of compensated signal with the uncompensated signal, e. g.: 0 %: 0 % compensated signal element, 100 % uncompensated signal component 10 %: 10 % of the compensated and 90 % of the uncompensated signals are calculated 100 %: the output signal contains 100 % of the compensated component
2.5.3	Ka	Input: 0.001 ... 65.535	Correction factor on the compensated signal! By the compensation the compensated signal can be at a significantly higher value level. To achieve a linear settlement of the two values (compensated and uncompensated) via the parameter intensity, the compensated value can be brought in the same order as the uncompensated value by using Ka.

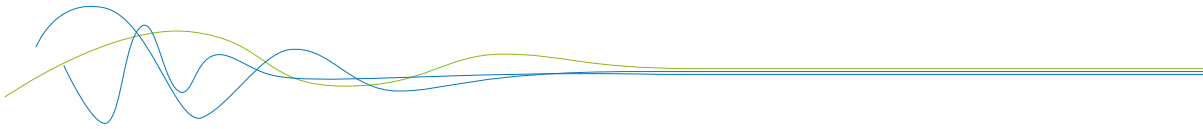

3. Alarm
Settings for relay contacts
- | | | | |
|-----|----------------|---------------------------------------|---|
| 3.1 | Alarm type | Selection: Min/Max/none | The relay is operated if the measurement exceeds or falls below the max. limit or min. limit. |
| 3.2 | Alarm value | Input: 0 ... 999.9 | limit value for monitoring Min. or Max. |
| 3.3 | Delay | Input: 0.1 ... 99.9 s | The value must permanently exceed or fall below the set limit during this time. |
| 3.4 | Hysteresis | Input: 0.1 ... 99.9 % | The alarm continues for as long as the measurement is not smaller or larger than the limit value plus or minus hysteresis. |
| 3.5 | Operation mode | Selection:
NC / NO | NC: the relay is closed while there is no alarm.
NO: the relay is closed, if there is an alarm. |
| 3.6 | Sensor alarm | Selection:
OFF / ERR / PROC | OFF: sensor or process errors will not activate the relay.
ERR: serious sensor errors lead to an alarm on the relay.
PROC: fatal sensor errors and process indicators lead to an alarm on the relay.
More information about the ERR and PROC signals, will be found in section error flags. |

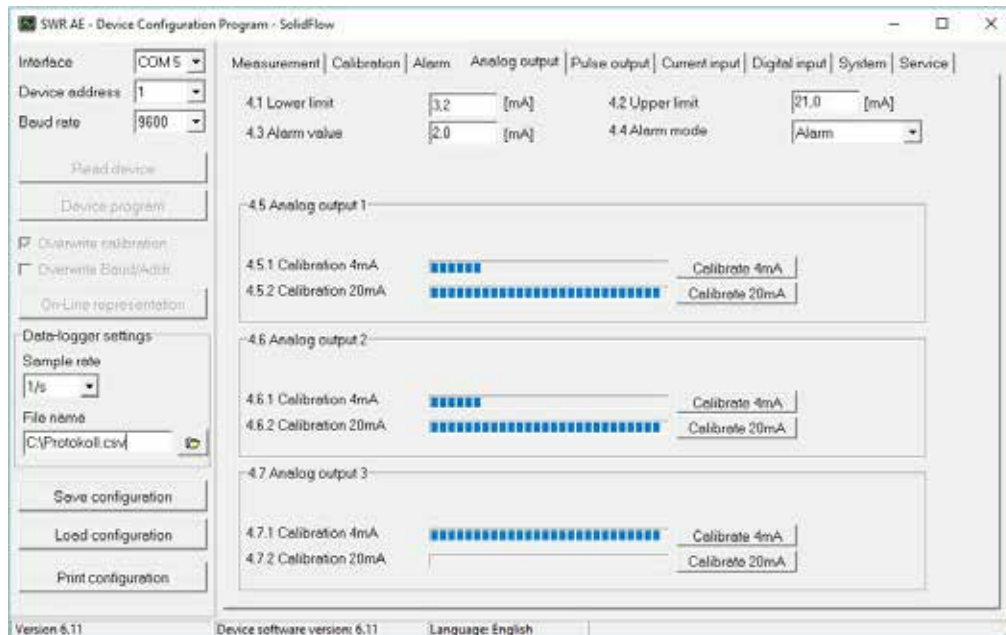
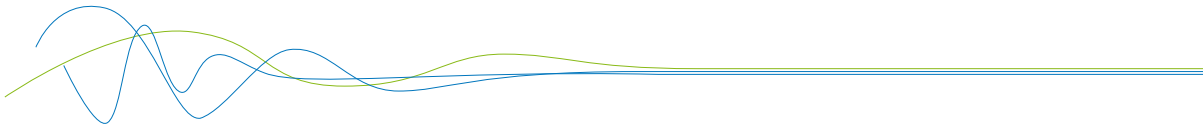

4. Analog output

Settings and calibration of analog output

4.1	Lower limit	Input: 0 ... 22 mA	Default settings: 4 mA
4.2	Upper limit	Input: 0 ... 22 mA	Default settings: 20 mA
4.3	Alarm value	Input: 0 ... 22 mA	Output value if a sensor alarm is given. Default settings: 2 mA
4.4	Alarm mode	Selection: alarm / freeze	Alarm: Alarm value at output, during alarm measuring value is 0. Freeze: Last measurement value would be freeze on Analogue output, till the error is fixed.
4.5	Analog output 1	Submenu	
4.5.1	Calibration 4 mA	Selection: set output current	The current output can be set via key functions and adjusted at the receiving end.
4.5.2	Calibration 20 mA	Selection: Set output current	The current output can be set via key functions and adjusted at the receiving end.
4.6	Analog output 2	Submenu	
4.6.1	Calibration 4 mA	Selection: set output current	The current output can be set via key functions and adjusted at the receiving end.
4.6.2	Calibration 20 mA	Selection: set output current	The current output can be set via key functions and adjusted at the receiving end.

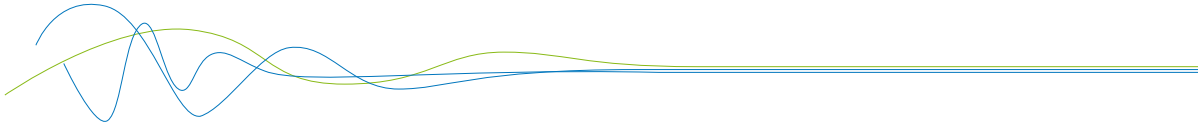

4.7	Analog output 3	Submenu	
4.7.1	Calibration 4 mA	Selection: set output current	The current output can be set via key functions and adjusted at the receiving end.
4.7.2	Calibration 20 mA	Selection: set output current	The current output can be set via key functions and adjusted at the receiving end.

The current output can be calibrated that the zero point (output of 4 mA) is applied to the background noise of the measuring point. If the noise level decreases due to process changes, material caking or other aging effects, less than 4 mA can be output at the analog output. In this way, a zero offset can be detected (zero point drift).

If this function is not required for process-technical reasons, the zero point must be set during calibration on a raw value of zero and / or the **4.1 Lower Limit** must be set to 4 mA.

If the settings of the 4 mA or 20 mA signal are changed, the checkbox **Overwrite calibration** must be set.

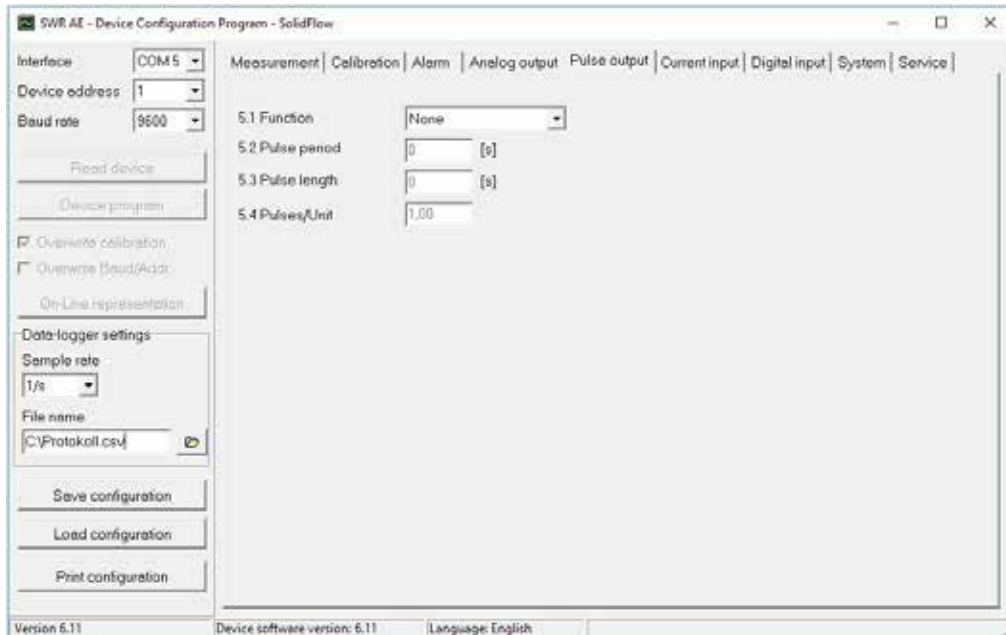
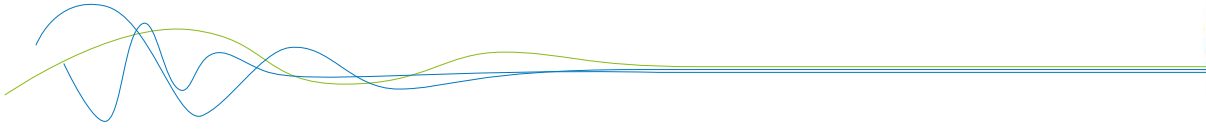

5. Pulse output

Passive signal for pulse cleaning or output of a totaliser.

5.1 Function:

Selection: none /
cleaning / quantity

None: No pulse output

Cleaning: Possibility to control a solenoid valve for compressed air-fluid.

5.4 Pulses/Unit without function.

Quantity: The quantity is send as an impulse sequence to the output; Unit is like **1.2 Unit**.

5.2 and **5.3 Pulse length** without function.

5.2 Pulse period:

Input: 1 s ... 600 s

Time between two impulses

5.3 Pulse length:

Input: 1 s ... 60 s

Length of impulse

5.4 Pulses/unit

Input: 0.01 ... 99.9

Number of pulses per unit

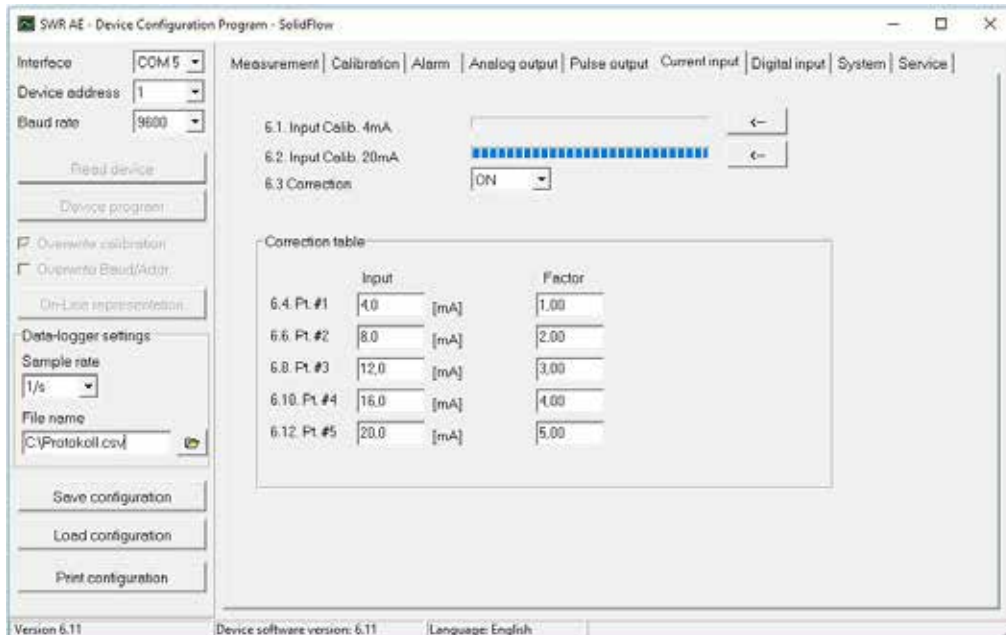
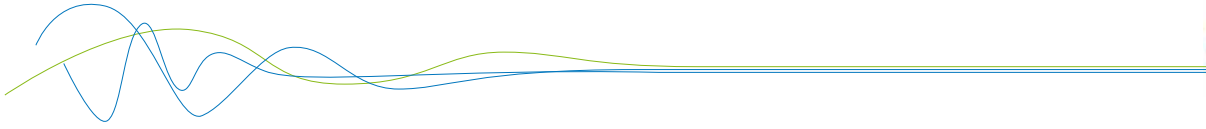

6. Analog input

Possibility of autocorrection via external current signal.

The connection of the current input is not galvanically isolated.

If the connection is incorrect, the CPU of the transmitter can be destroyed. An external galvanic isolation, by current disconnecter or similar shall be provided.

6.1 Input calibration 4 mA

Selection:
calibrate 4 mA input

The 4 mA signal must be read in via key function.

6.2 Input calibration 20 mA

Selection:
calibrate 20 mA input

The 20 mA signal must be read in via key function.

6.3 Correction

Selection: ON / OFF

ON: Correction is activated.
OFF: Correction is disabled.

6.4 P1-input

Input: 4 mA ... 20 mA

Enter the current strength to be used for correction.

6.5 P1-factor

Input: 0.01 ... 10

Factor for adjustment of the actual measured value.

6.n Pn-input

Input: 4 m A ... 20 mA

Possibility of further current values and correction factor.

6.n Pn-factor

Input: 0.01 ... 10

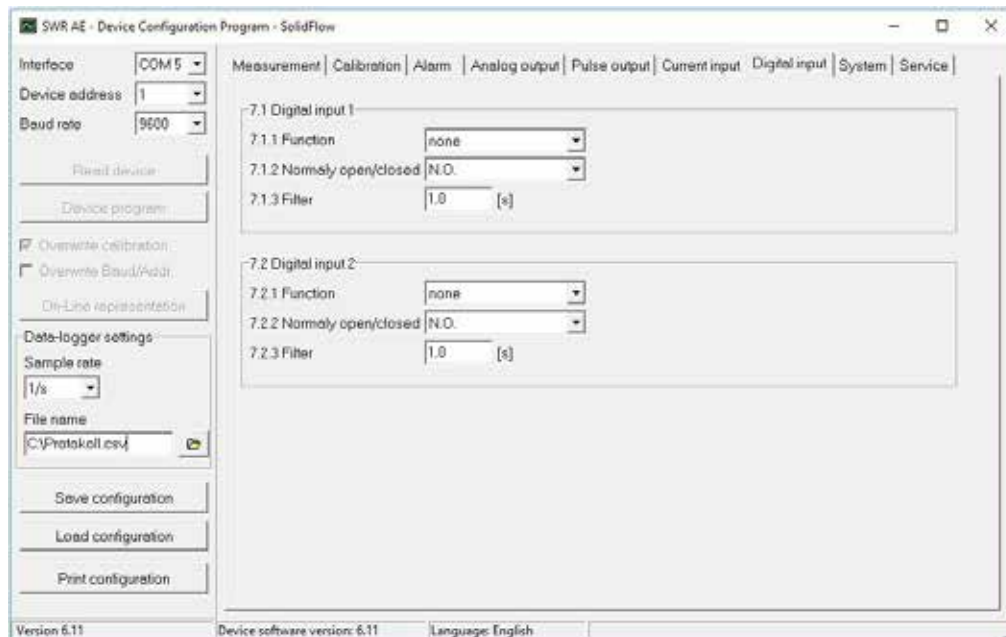

7. Digital input

Selection of function for external control.

7.1 Digital input 1

Submenu

7.1.1 Function

Selection:

none / reset totaliser /
AutoCal

None: Digital input disabled.

Reset totaliser: Totalisator would be
reset to zero.

AutoCal: An auto calibration will be start.

7.1.2 Working direction

Selection: NO / NC

If necessary, invert the value of the input
level.

7.1.3 Filter

Input: 0.1 ... 99.9 s

Time during which the requested signal must
remain pending.

7.2 Digital input 2

Same as digital input 1

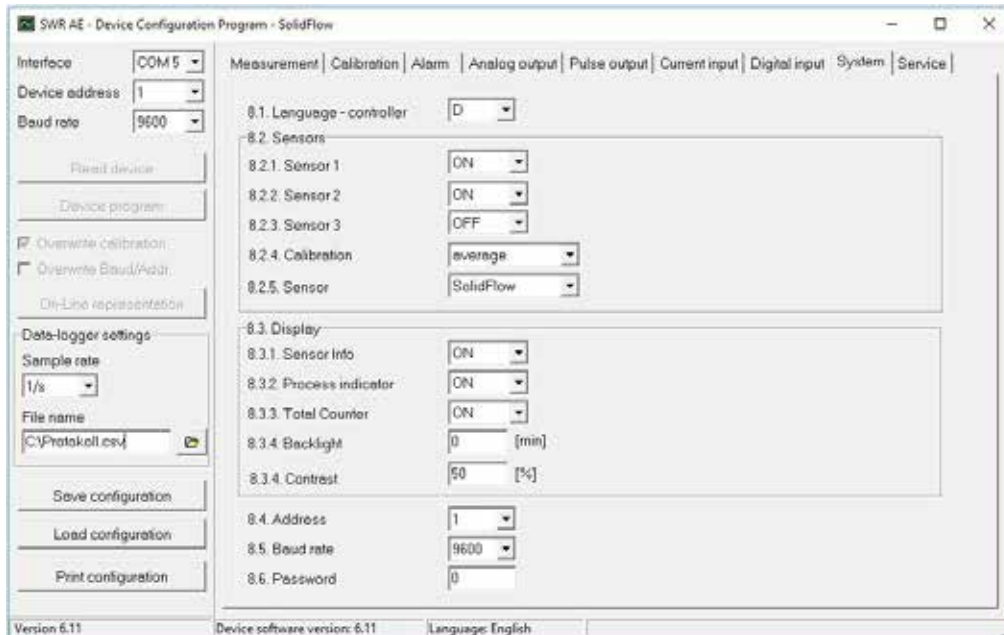
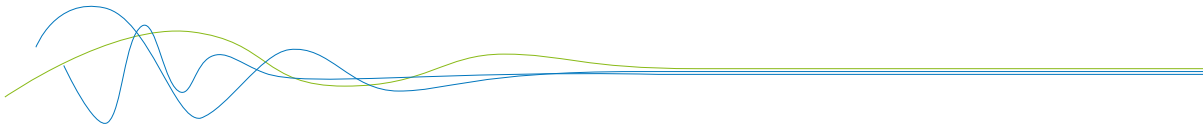

8. System

Basic adjustment of the system and transmitter.

8.1 Language **Selection:** D / E / F Language on the transmitter

8.2 Sensors **Sensor function and calibration**

8.2.1 Sensor 1 **Selection:** on / off **ON:** Sensor is evaluated.
OFF: Sensor is ignored.

8.2.2 Sensor 2 **Selection:** on / off **ON:** Sensor is evaluated.
OFF: Sensor is ignored.

8.2.3 Sensor 3 **Selection:** on / off **ON:** Sensor is evaluated.
OFF: Sensor is ignored.

8.2.4 Calibration **Selection:** single / average **This function is used only for multi-sensor systems!**

Single: Calibration of single sensors:
Each sensor is converted via an individual calibration table from the raw value to the throughput, after that the calculation of average throughput on the throughput values of the individual sensors is taking place.

(This function should only be used by trained personnel of ENVEA - SWR engineering.)

Average: Calibration by the average value from raw values:

The throughput will be calculated with a common calibration table after forming the average from raw values.

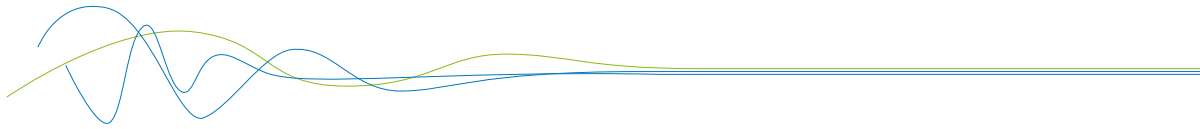

8.2.5	Sensor	Selection: SolidFlow 2.0 / PicoFlow / ProSens / SpeedFlow 2.0 / PADDY / MaxxFlow HTC / DensFlow / SlideControl / M-Sens 2 / M-Sens 2 FD / M-Sens WR	The transmitter verifies the availability of registered sensors on the selected type, calculates the measurement values on this basis and signals if necessary corresponding errors. Incorrect sensor selection leads to a refusal to communicate.
8.3.	Display	Submenu	
8.3.1	Sensor info	Selection: ON / OFF	ON: Show info key on display OFF: Hide info key
8.3.2	Process indicator	Selection: ON / OFF	ON: Process indicators will be shown on display and via double blink on the DIN Rail. OFF: Process indicators will not be shown.
8.3.3	Totalisator	Selection: ON / OFF	ON: Totalisator will be shown on display. OFF: Totalisator will be hide.
8.3.4	Backlight	Input: 0 ... 99 min	Lighting of the Display in minutes 0 = permanent lighting 99 = time selection for lighting
8.3.5	Contrast	Input: 0 ... 100 %	In the case of display exchange, the contrast can be changed via the PC software, if necessary.
8.4	Address	Input: 1 ... 255	ModBus address of transmitter, if operated on a PLC or PC as a slave.
8.5	Baud rate	Selection: 4800/9600/19200/ 38400 baud	Communication speed of the transmitter when this is operated as a ModBus slave on a PLC or a PC.
8.6	Password	Input: 0 ... 9999	0000 = No password XXXX = Four-digit password, which is queried when the menu is called up on the display. Automatic lock five minutes after the last display input.

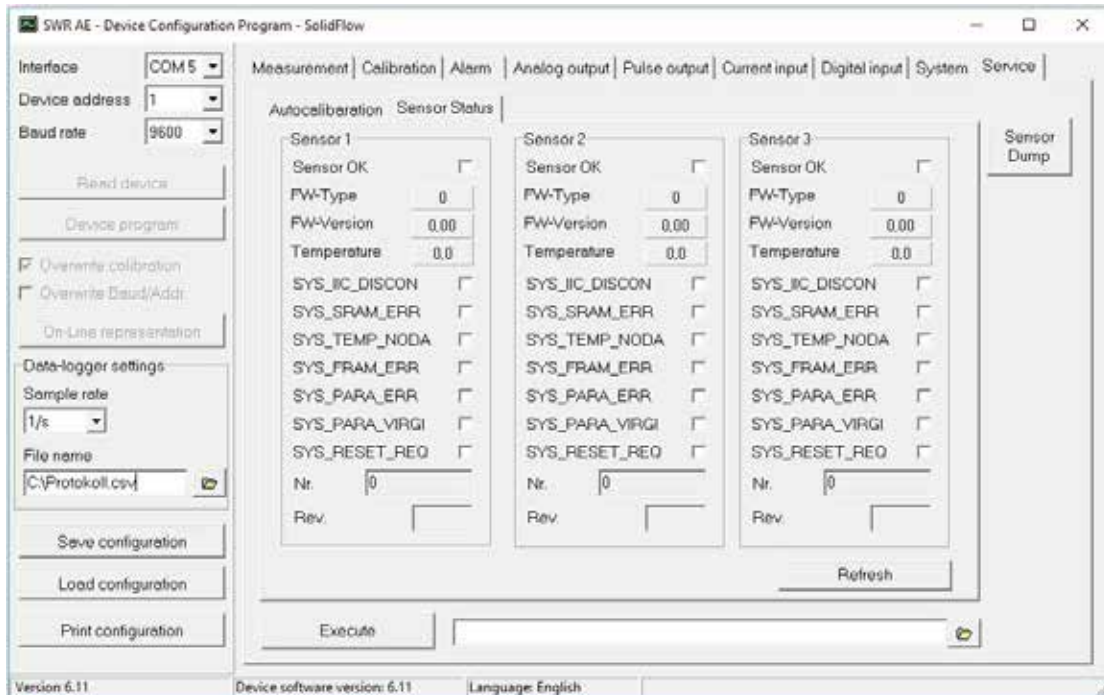
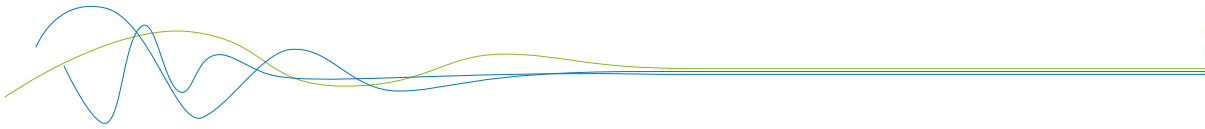

9. Service

Display on the sensor status

The status of each connected sensor is displayed in menu **9. Service**. FW type, FW version, temperature, serial number and possible hardware errors are automatically read and displayed.

Only according to instructions from personnel of ENVEA - SWR engineering:

If a detailed error analysis is necessary, a copy of all ModBus registers can be stored as a text file in the installation folder of the software by clicking on the **sensor dump**. This is only possible with the PC software.

In addition, a software with deeper access to the sensors can be started via the PC software.

On the touchscreen only the information of the individual sensor will be shown.

7. Start-up procedure

7.1 Basic start-up

Upon delivery, the sensor is not calibrated to the product to be measured and must be parameterised when started up. During the process, the mass flows measured by the sensor are assigned the display values and output quantities required by the user.

The following points must first be checked:

- Check sensor is flush with the internal surface of the pipeline.
- The correct connection between the sensor and the transmitter.
- A warm-up time of approx. 5 minutes before starting calibration and after switching on the sensor's power supply.

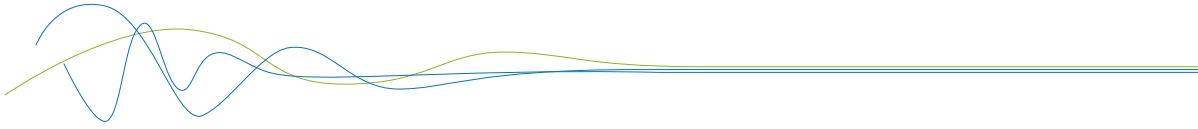

At the beginning of the calibration, it must be checked whether the correct sensor is selected under the menu item **System**. If the correct sensor has been selected, the desired measuring range and the physical unit can be entered under **1. Measurement**. The **1.2 Unit** is a free text, there are 10 characters available. The calibration of the system is carried out on at least two calibration points in **2. Calibration**.

Min point	The first calibration point will be set at running process, but without any product. For calibration of this zero point it must be given a "0" on 2.4.1 Val. P1 , afterward the RAW value (2.4.2 Calib. P1) must be calibrate. The RAW-value could be calibrated by reading the sensor directly or manually by calculate the RAW value over the datalogger in the software.
Working point	During normal conveyance, the second point will be set. The flow rate will type in 2.4.3 Val. P2 and the RAW-value will be read direct under 2.4.4 Calib. P2 or could be calculate manually by using the datalogger in the software. The value can be corrected afterwards during weighing. Once the calibration points have been saved, the transfer of the calibration parameters must be confirmed. On the transmitter in the field housing, this is done by a security query when leaving the menu structure. In the software the checkmark on Overwrite calibration must be set. If the checkbox is set, the parameters can be transferred to the transmitter by clicking on device program .

The device has thus performed its basic function and the measurements are displayed.

Additional support points If non-linearities occur when measuring with different flow rates, up to 5 support points can be selected in **2.3 calibration points**. These support points could be calibrated with different flow rates.

7.2 Data logger function in the software

To determine the raw values via the data logger function in the PC software, a file path must first be stored. The file path and file name can be selected after clicking on the folder icon (next to file name). Once the file path has been stored, it is still possible to change the storage rate. This is recommended for long-term logging. To determine the raw values for a calibration point, the default setting of 1 (raw value) per second is recommended.

To start the data logger, the **On-Line representation** must be opened. As soon as the tick is set by **Data logger activated** in the On-Line representation, the recording starts and the log file is created in the background.

To evaluate the recorded log file, it must be opened with Excel or a similar program.

The content of each column of the log file is named in the first line.

In order to determine the appropriate raw value for a calibration point, the mean value must be determined from the time period of the coarse material addition, or from the stable "clean" material flow. The mean value can be calculated by Excel using the function `=AVERAGE()`. The calculated mean value of the raw value is then entered in the box next to **Raw value** in the configuration software.

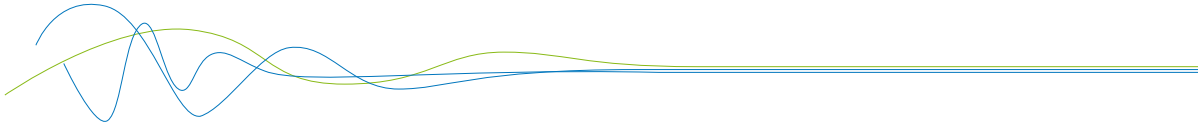

7.3 Adjusting the measurement values

The system's additional functions can be set in the following menus:

Alarms	Values for flow rate lower or upper limits can be set in 3. Alarm . A sensor monitoring alarm can also be activated here.
Analogue output	The assignment of the analogue output values takes place in 4. analogue output. Upper and lower limit of the permitted current and the fault current are set here. The analogue output is an active signal. In the field housing version, analogue outputs 2 + 3 are provided for the MaxxFLOW HTC. All other sensors provide their 4 ... 20 mA signal to analogue output 1.
Pulse output	Under 5. Pulse output there is the possibility of using different impulses. A cleaning pulse can be used for a pneumatic cleaning on the sensor. For an external totaliser output there are impulses, which correspond to a specific conveyed mass. The pulse duration is 50 Hz, a faster query cannot be guaranteed. An internal totaliser function integrates the mass flow over time. The pulse output is an open collector and need an active power supply for pulsing.
Current input	Various input currents can be stored under 6. Current input . When the current is applied, the corresponding correction factor is applied to the measured value. The input current also must be adjusted here.
Digital input	In 7. Digital input , the system's digital inputs can be assigned various functions and their working direction.
System	In 8. System , functions such as selection of the menu language, the number of connected sensors and their average, the display screen or ModBus addressing and speed are summarised.
Totaliser	The entire flow volume since the last totaliser reset can be read with the totaliser function. A reset can be performed via an external control cable or directly via the display by pressing the R symbol.

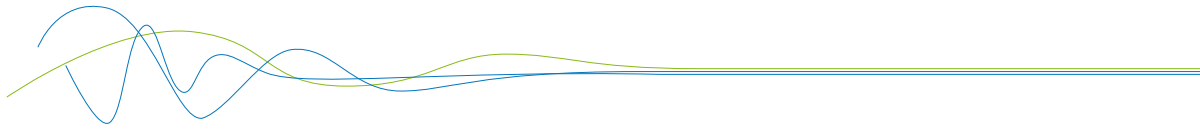

8. Error signalling

For monitoring the availability a wide range of functions for self-diagnostics were integrated, in order to signal various errors:

1. Fatal error (ERR):

Fatal errors (ERR) always set the current output to the set alarm value. Technical problems or problems with the complete system are displayed on the touchscreen. An ERR require every time a replacement or repair of a component:

- Failure of the communication to a sensor (sensor failure)
- Failure of a subcomponent of a sensor (temperature monitoring, heating control, memory, data consistency etc. on the sensor)
- Inconsistency of signal paths in the sensor (the amplifier stages, DC offsets)

2. Process indicators (PROC):

Process indicators (PROC) are merely a violation of the set parameters and are to be understood as information to improve the measuring process. Process indicators are not output at the current output, but can be displayed on the display (field housing) or the RUN LED (DIN Rail) as well as optionally on the relay:

- Temperature instability in the sensor due to thermal stress from outside (over-temperature, low temperature)
- Overload of the sensor caused by material flow (too much, too little)

Process indicators show if necessary temporary appearing oddities in the process, which can be avoided with a better adjustment of sensor parameters or conveying parameters. They thus deliver more an indication of potential for optimization at the measuring point.

Type of fault	Display (field housing)	Run-LED (DIN Rail)	Relay (optional)	Current output
No fault	Sensor status OK on the information display (Button [I])	Single flash every second	Normal state	4 ... 20 mA
PROC (process indicators)	Display with indicator code in the bottom display line; advanced information on key [I]	Double flash every second	Activated, when Relais-Alarm-Option PROC is chosen	4 ... 20 mA
ERR (fatal errors)	Display with error code in the bottom display line; advanced information on key [I]	Triple flash every second	Activated, when Relais-Alarm-Option PROC <u>or</u> ERR is chosen	2 mA (or for the current output adjusted, chosen alarm value)

Error codes: Error and indicator codes are composed of the letter E (ERR = error), P (PROC = process indicator) and a three-digit hexadecimal value from "000" to "FFF". From the displayed code the cause can be investigated.

Time out error: In order not to complicate the start up of a process plant by process- or heating status errors, nonfatal errors will be signalled only after a period of about 5 minutes after a reset of the measuring system at the outputs. The time-out period is visible in a small "t" in the left upper corner of the display (field housing only).

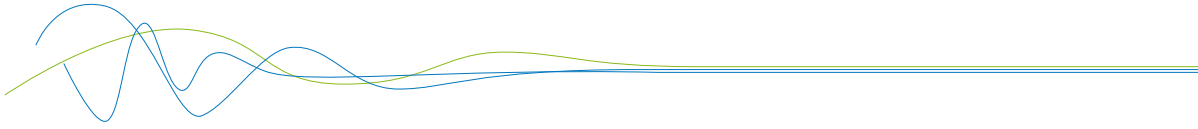

8.1 Compatibility

For the SolidFlow 2.0 systems three different software versions for the transmitter and associated PC software are available.

Technical innovations have caused a supplement of new functions, so that only the corresponding versions can be used together on transmitter and PC:

Sensor	Transmitter (field housing or DIN Rail)	PC software
All SolidFlow 2.0		
	all transmitters with FW version 3.xx	Versions up to V.5.01
	all transmitters from FW version 5.03	Versions from V.5.03
	all transmitters from FW version 6.xx	Versions from V.6.01

8.2 History of versions

FW V.3.xx / V.5.01:

- fully functional release for transmitter and PC

FW V.5.03 / V.5.03:

- improvement of error monitoring (ERR, PROC)
- change from fixed point to floating-point values in the calibration table
- introduction of product variant PicoFlow
- zero drift detection for the current output
- parameters KA for rope compensation
- error-timeout for the reset

FW V.6.00 / V.6.01

- possibility for evaluate: ProSens, SpeedFlow 2.0, PADDY, MaxxFlow HTC
- current input for auto correction
- pulse output for control of solenoid valves for pneumatic cleaning
- possibility to calibrate a low flow
- improved error signalling

9. Maintenance



Warning!

- Switch the power supply off before performing any maintenance or repair work on the measuring system. The transport pipe must not be operational when replacing the sensor.
- Repair and maintenance work may only be carried out by electricians.
- The system requires no maintenance.

10. Warranty

On condition that the operating conditions are maintained and no intervention has been made on the device and the components of the system are not damaged or worn, the manufacturer provides a warranty of 1 year from the date of delivery.

In the event of a defect during the warranty period, defective components will be replaced or repaired at ENVEA - SWR engineering's plant free of charge as considered appropriate. Replaced parts will become ENVEA - SWR engineering's property. If the parts are repaired or replaced at the customer's site at its request, the customer must pay the travel expenses for ENVEA - SWR engineering's service personnel.

ENVEA - SWR engineering cannot accept any liability for damage not suffered by the goods themselves and in particular ENVEA - SWR engineering cannot accept liability for loss of profit or other financial damages suffered by the customer.

11. Fault clearance



- Warning!**

The electrical installation may only be inspected by trained personnel.

Error	Cause	Action
Measuring system does not work.	Power supply interrupted.	Check the power supply.
POW LED does not light up.	Cable break.	Check the connection cables for a possible cable break.
RUN LED does not light up.	Defective fuse.	Replace fuse.
	Defective device.	Notify ENVEA - SWR engineering and rectify the error as instructed on the telephone.
Measuring system does not work.	Microprocessor does not start.	Switch the power supply off and on again.
POW LED does light up.		Remove programming cable.
RUN LED does not light up.		
Measuring system works.	No sensor communication.	Sensor defective. Cable break between sensor and measuring system.
POW LED does light up.	Sensor connected incorrectly.	Check connection cable.
RUN LED flashes two or three times per cycle.	Sensor defective.	Replace sensor.
	Sensor not receiving 24 V supply.	Make sure the power supply is connected.
	Excessive voltage drop in the supply cable to the sensor.	Check cable lengths.
	Error code on display available.	Further error diagnosis by error code.
Measuring system outputs incorrect values.	Calibration incorrect.	Perform a recalibration.
	Calibration shifted by abrasion on the sensor head.	Perform a recalibration.
Switch output relay chatters.	Hysteresis too low.	Increase hysteresis. Check for fault caused by external consumer.

The warranty will be rendered void if you open the device.

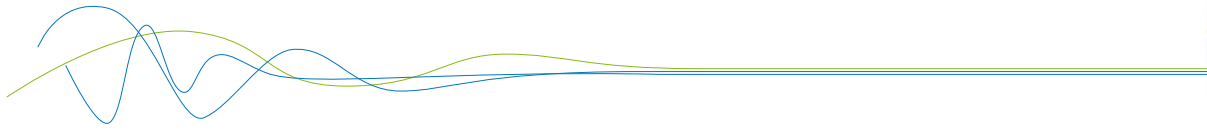

11.1 Error codes

Type	Code	Transmitter flashing	Current output	Cause	Action
ERR	DISC	3	2 mA	Wrong sensor connection, wrong sensor or sensor would not detect	Proof of cabling, voltage, earthing and software parameter
ERR	ID	3	2 mA	Sensor respond with wrong ID	Check if the correct sensor is chosen in the menu
ERR	E002	3	2 mA	Defective data bus	Turn power off / on. If not helpfully sensor exchange
ERR	E020	3	2 mA	Defective memory	Turn power off / on. If not helpfully sensor exchange
ERR	E040	3	2 mA	Defective internal temperature measurement	Turn power off / on. If not helpfully sensor exchange
ERR	E080	3	2 mA	Defective parameter memory	Turn power off / on. If not helpfully sensor exchange
ERR	E100	3	2 mA	Parameter table not readable	Turn power off / on. If not helpfully sensor exchange
ERR	E200	3	2 mA	Parameter table not written	Turn power off / on. If not helpfully sensor exchange
ERR	E400	3	2 mA	Rest request not executable	Turn power off / on. If not helpfully sensor exchange
ERR	E001	3	2 mA	Defective internal amplifier (DC Offset)	Turn power off / on. If not helpfully sensor exchange
ERR	E200	3	2 mA	Defective internal amplifier (channel)	Turn power off / on. If not helpfully sensor exchange
ERR	UT-K	3	2 mA	Critical low temperature, no output measuring value	Proof heater, wait for heating time, insulate cold sources
ERR	OT-K	3	2 mA	Critical high temperature, no output measuring value	Insulate hot sources
PROC	UT	2	4 ... 20 mA	Low temperature, Warning: unreliable output measuring value	Proof heater, wait for heating time, insulate cold sources
PROC	OT	2	4 ... 20 mA	High temperature, Warning: unreliable output measuring value	Insulate hot sources
PROC	P010	2	4 ... 20 mA	Measuring value low limit	Adjust alarm value, for test increase the material flow
PROC	P040	2	4 ... 20 mA	Measuring value high limit	Adjust alarm value, for testing reduce the mass flow
PROC	P000	2	4 ... 20 mA	Measuring value deliver zero quality	Proof build in situation and material flow

A detailed error description and following troubleshooting can be carried out by trained ENVEA - SWR engineering technicians.

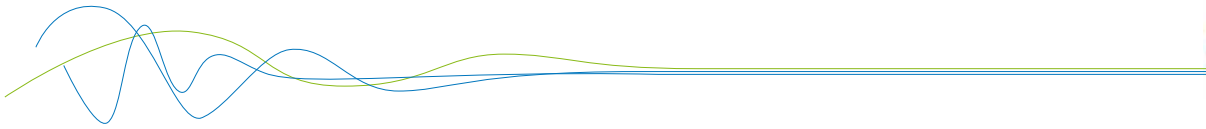

12. Connection examples

12.1 Digital input

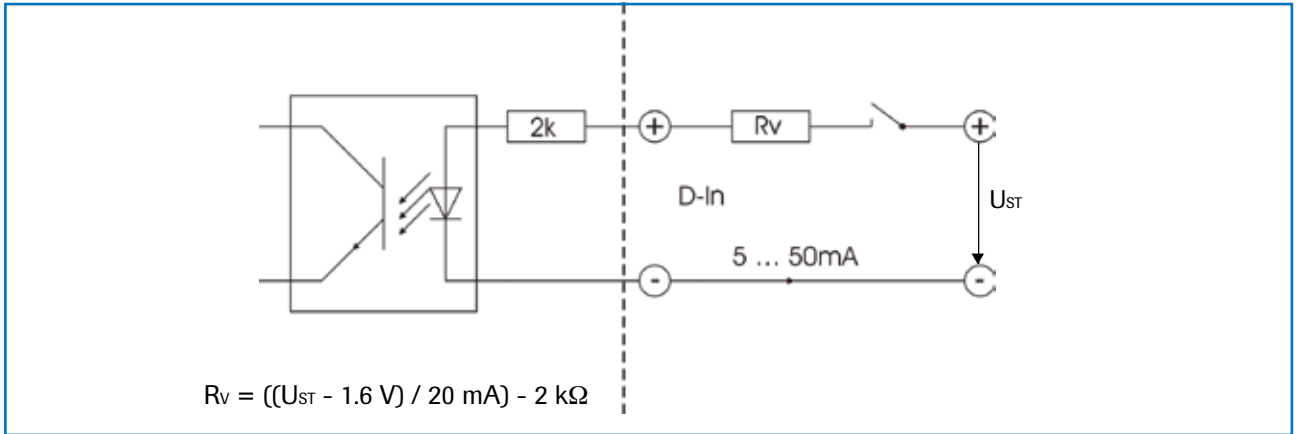

12.2 Impulse output

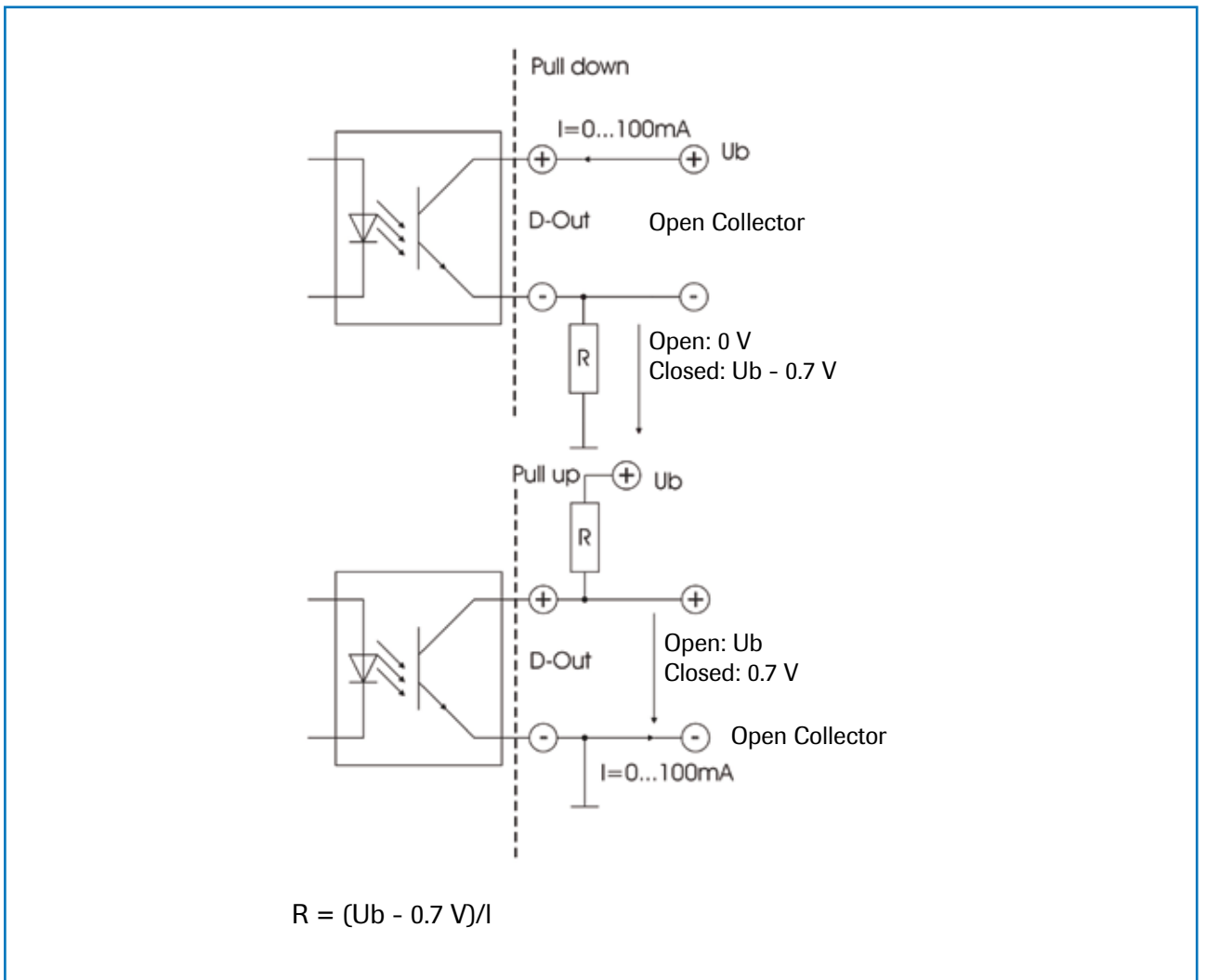

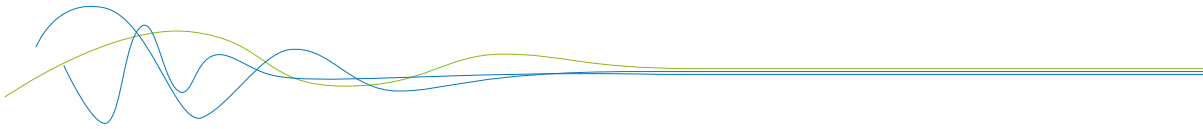

13. ATEX certificate

Translation

(1) **3rd Supplement to the EC-Type Examination Certificate**

(2) Equipment and protective systems intended for use in potentially explosive atmospheres - Directive 94/9/EC Supplement accordant with Annex III number 6

(3) No. of EC-Type Examination Certificate: **BVS 04 ATEX E 056**

(4) Equipment: **Mikrowellensensor type Solid Flow *Ex**

(5) Manufacturer: **SWR engineering Messtechnik GmbH**

(6) Address: **Gutedelstraße 31, 79418 Schliengen, Germany**

(7) The design and construction of this equipment and any acceptable variation thereto are specified in the appendix to this supplement.

(8) The certification body of DEKRA EXAM GmbH, notified body no. 0158 in accordance with Article 9 of the Directive 94/9/EC of the European Parliament and the Council of 23 March 1994, certifies that this equipment has been found to comply with the Essential Health and Safety Requirements relating to the design and construction of equipment and protective systems intended for use in potentially explosive atmospheres, given in Annex II to the Directive. The examination and test results are recorded in the Test and Assessment Report BVS PP 04.2036 EG.

(9) The Essential Health and Safety Requirements are assured by compliance with:

EN 60079-0:2012 + A11:2013	General requirements	
EN 60079-1:2014	Flameproof enclosure "d"	
EN 60079-31:2014	Protection by enclosure "t"	

(10) If the sign "X" is placed after the certificate number, it indicates that the equipment is subject to special conditions for safe use specified in the appendix to this certificate.

(11) This supplement to the EC-Type Examination Certificate relates only to the design, examination and tests of the specified equipment in accordance to Directive 94/9/EC. Further requirements of the Directive apply to the manufacturing process and supply of this equipment. These are not covered by this certificate.

(12) The marking of the equipment shall include the following:

	II 2G Ex db IIC T5 Gb	Type Solid Flow GasEx
	II 1/2D Ex ta/tb IIIC T84°C Da/Db	
	II 1/2D Ex ta/tb IIIC T84°C Da/Db	Type Solid Flow dEx

DEKRA EXAM GmbH
Bochum, dated 2015-09-17

Signed: Simanski

Certification body

Signed: Dr. Wittler

Special services unit

Page 1 of 3 of BVS 04 ATEX E 056 / N3

This certificate may only be reproduced in its entirety and without any change.

DEKRA EXAM GmbH, Dinnendahlstrasse 9, 44806 Bochum, Germany, telephone +49.234.3696-105, Fax +49.234.3696-110, zs-exam@dekra.com

(13) Appendix to

(14) 3rd Supplement to the EC-Type Examination Certificate
BVS 04 ATEX E 056

(15) 15.1 Subject and type

Microwave Sensor type Solid Flow *Ex

└─── d	for use in potentially hazardous areas caused by dust atmosphere
Gas	for use in potentially hazardous areas caused by gas atmosphere or for use in potentially hazardous areas caused by dust atmosphere

15.2 Description

The microwave sensor Type Solid Flow *Ex serves to measure the quantity of solids conveyed in pipes.
The sensor can be installed in zone 1 or in the partition wall between zone 20 and zone 21. In that case only the tip of the sensor is located in zone 20 whereas the main part of the sensor is in zone 21.
The equipotential bonding is realized by installing the sensor at the earthed pipeline.
The reason for this supplement is the updating to the current standards.

15.3 Parameters

15.3.1 Electrical data

15.3.1.1 Supply

Voltage	DC	24	V
current	max.	0.5	A

15.3.1.2 Output MOD-Bus via RS485

voltage	max.	0.5	V
current	max.	100	mA
frequency		10... 2200	Hz
radiant emittance of the sensor	max.	3	mW, continuous wave

15.3.2 Thermal data

15.3.2.1 Type Solid Flow dEx

maximum surface temperature T (limited by thermo fuse)	84	°C
permitted process temperature range (at the tip of the sensor, zone 20)	0 up to 80	°C
permitted ambient temperature range (zone 21)	-10 up to 60	°C

15.3.2.2 Type Solid Flow GASEx

maximum surface temperature T (limited by thermo fuse)	84	°C
permitted ambient temperature range	-10 up to 60	°C
permitted process temperature range (at the tip of the sensor, zone 20)	0 up to 80	°C
temperature class at a process temperature of max. 80 °C	T5	
temperature class at a process temperature of max. 150 °C	T3	

15.3.3 Degrees of protection according to EN 60529	IP 65
--	-------

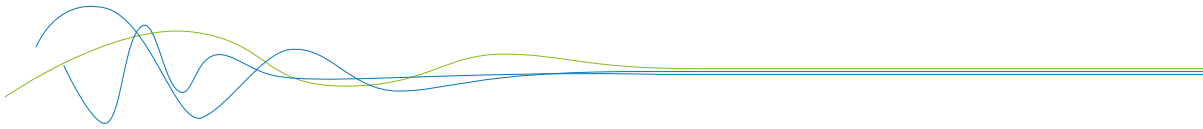

(16) Test and Assessment report

BVS PP 04.2036 EG as of 2015-09-17

(17) Special conditions for safe use

None

We confirm the correctness of the translation from the German original.
In the case of arbitration only the German wording shall be valid and binding.

DEKRA EXAM GmbH
44809 Bochum, 2015-09-17
BVS-Hk/Nu A 20150817

Certification body

Special services unit



Page 3 of 3 of BVS 04 ATEX E 056 / N3
This certificate may only be reproduced in its entirety and without any change.

DEKRA EXAM GmbH, Dinnendahlstrasse 9, 44809 Bochum, Germany,
telephone +49.234.3696-105, Fax +49.234.3696-110, zs-exam@dekra.com

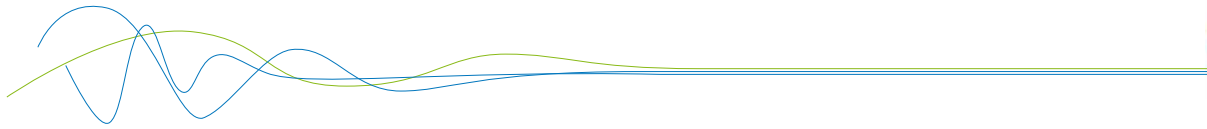

13. Technical data

Sensor / Sensor accommodation	
Housing	Aluminium
Protection category	IP 66
Operating temperature	-20 ... + 60 °C (max. 150 °C)
Max. working pressure	10 bar
Weight	1.5 kg
Sensor rod	Material: ceramic protected stainless steel; max. 450 mm
Accuracy	± 5 % in calibrated range
Field housing transmitter	
Power supply	110/230 V, 50 Hz (optional 24 V DC)
Power consumption	20 W / 24 VA
Protection category	IP 65 to EN 60 529/10.91
Ambient operating temperature	-10 ... +45 °C
Dimensions	258 x 237 x 174 (W x H x D)
Weight	Approx. 2.5 kg
Interface	RS 485 (ModBus RTU) / USB
Cable screw connectors	3 x M20 (4.5 - 13 mm Ø)
Connection terminals cable cross-section	0.2 - 2.5 mm ² [AWG 24-14]
Current output	3 x 4 ... 20 mA (0 ... 20 mA), load < 500 Ω
Relay contact	Max. rated load: 250 V AC Max. peak current: 6 A Max. rated load 230 V AC: 250 VA Max. breaking capacity DC1: 3/110/220 V: 3/0.35/0.2 A Min. swithing load: 500 mW (10 V/5 mA)
Data backup	Flash memory
Pulse output	Open Collector - max. 30 V, 20 mA
DIN Rail transmitter	
Power supply	24 V DC ± 10 %
Power consumption	20 W / 24 VA
Protection type	IP 40 to EN 60 529
Ambient operating temperature	-10 ... +45 °C
Dimensions	23 x 90 x 118 (W x H x D)
Weight	Approx. 172 g
Interface	RS 485 (ModBus RTU) / USB
DIN Rail fastening	DIN 60715 TH35
Connection terminals cable cross-section	0.2 - 2.5 mm ² [AWG 24-14]
Current output	1 x 4 ... 20 mA (0 ... 20 mA), load < 500 Ω
Relay contact	Max. rated load: 250 V AC Max. peak current: 6 A Max. rated load 230 V AC: 250 VA Max. breaking capacity DC1: 3/110/220 V: 3/0.35/0.2 A Min. swithing load: 500 mW (10 V/5 mA)
Data backup	Flash memory
Pulse output	Open Collector - max. 30 V, 20 mA



SWR engineering Messtechnik GmbH

Gutedelstraße 31 · 79418 Schliengen (Germany)

Fon +49 7635 827248-0 · Fax +49 7635 827248-48 · www.swr-engineering.com

PART OF THE ENVEA GROUP

