

DensFlow

Flow-measurement
for dense-phase-conveying

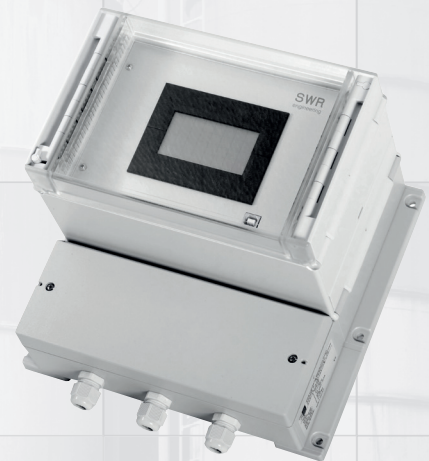
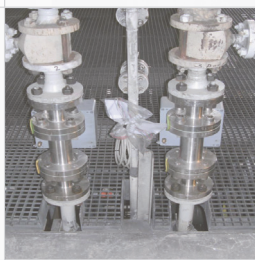
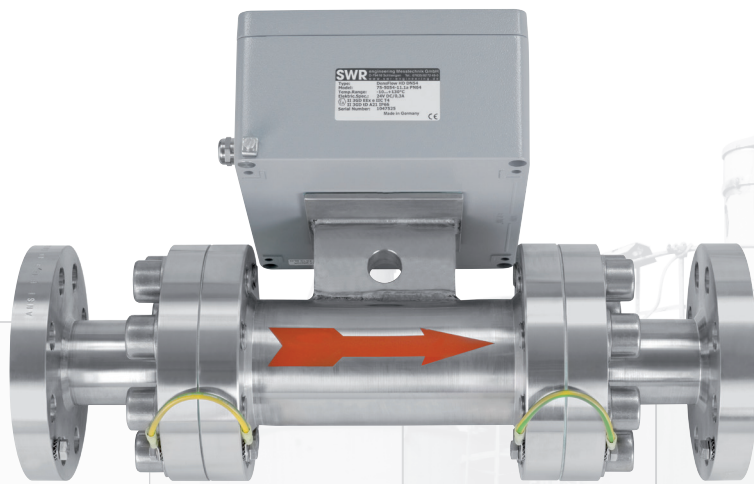

Using

DensFlow is a measuring system especially developed for measuring the flow rate of conveyed solids in dense-phase. DensFlow is used for the online-measuring of:

- all types of powder or granulates
- pneumatically densephase conveyed materials
- after mechanical conveying systems like chutes, slides or downpipes
- with large flow rates
- high-pressure applications up to 64 bar

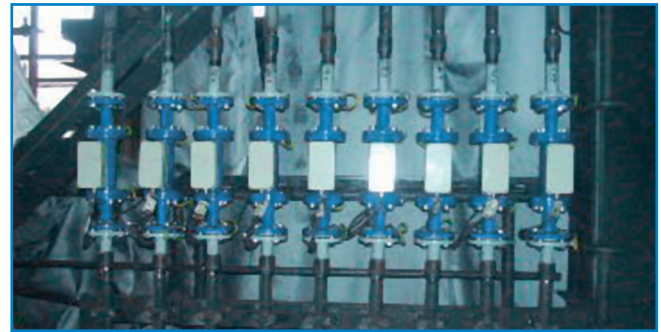

Function

In the measuring pipe a homogeneous measuring field is produced by special linking of a high frequency, electromagnetic alternating field. Solids, which are within this measuring field, absorb the energy of this alternating field. This leads to a measuring signal according to the concentration of the conveyed material in the measuring pipe (kg/m^3). The speed is measured within the measuring tube by means of two further electrodes. The speed measurement works on the basis of electrodynamics.

The passing and impingement of the solid particles leads to a charge transfer. These signals are fed to a correlator, which determines the transit time between the two electrodes exactly. Due to the defined distance between the two electrodes, a highly accurate speed measurement is possible. From the two measured values concentration (K) and velocity (V) as well as the known cross section (A) of the measuring pipe then the flow rate is determined according to:

$Q = K \times V \times A$ and evaluated as a 4...20 mA-signal.

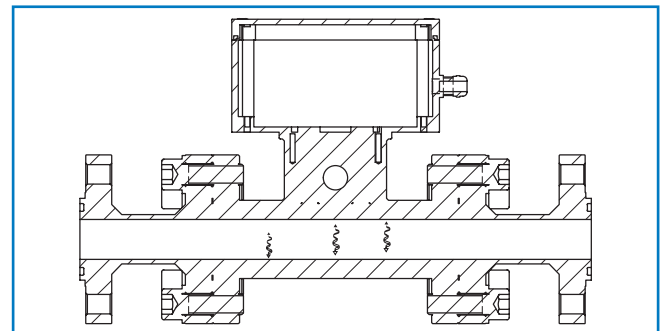

System

A complete measuring unit consists of the following components:

- Sensor (measuring pipe) for installation into the pipe
- Transmitter MSE 300

For the connection between transmitter and sensor, a four-wire, paired and shielded cable is required. The evaluation unit can be installed at a maximum distance of 300 m from the sensor.

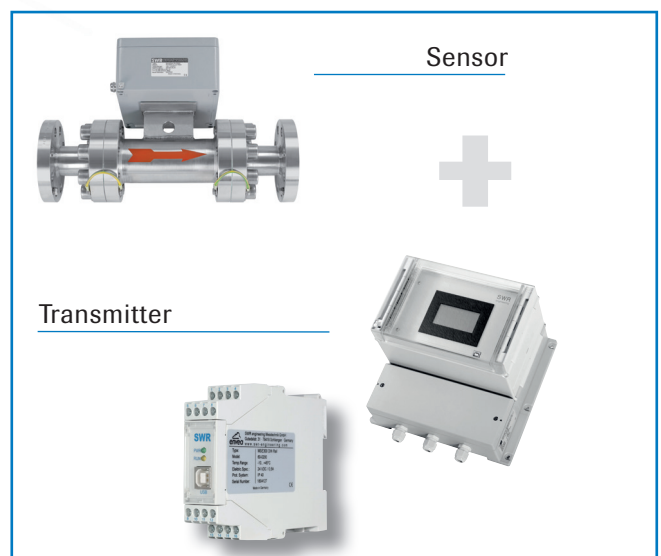

Applications – practical examples

▪ Fuel conveying

At blast furnaces or combustion plants fuels are supplied in a densephase conveyed manner by several fuel lines to the combustion. Combustion is optimal and most efficient, if the flow rate is equal in all pipes. DensFlow measures the instantaneous mass flow in each single pipe, which then can be regulated by control valves.

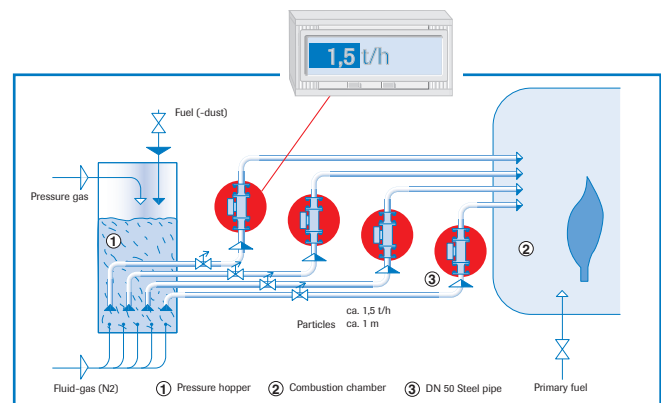

▪ Careful conveying in densephase

Many solids, which are mostly very expensive, are transported in a slow, material-careful densephase conveyed manner. DensFlow supplies precious measured values for the velocity of the solids and the quantity in order to optimise the transport of solids.

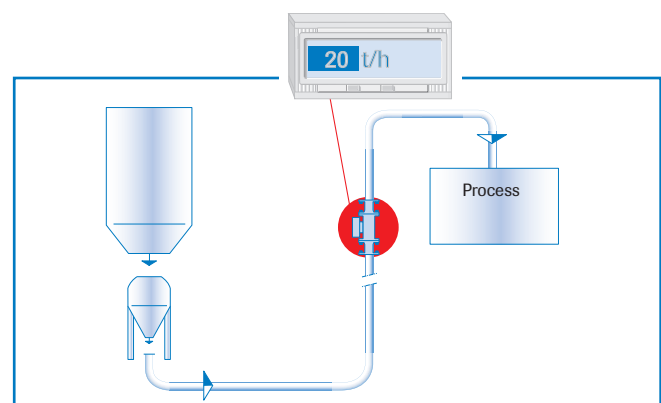

Benefits

- Installation cross section free, therefore columns and built up impossible
- Flow rates unlimitedly measurable
- Measurement independent of the material's velocity
- Easy retrofitting
- Maintenance free
- Measuring system without contact (no mechanics)
- Possible use under high pressure (max. 64 bar)

Mounting and installation

With pneumatically densephase conveyed materials the fitting position will be determined according to the necessary inlet and outlet section.

When mounting the measuring system after mechanical conveyed feeders there is usually no special inlet section necessary, for the material flow is uniform* after the feeder (* equal direction of the material flow, no turbulences or different flow directions of solid particles).

At the determined mounting position the measuring pipe will be fixed by means of a flange. Measuring pipes are available standard in nominal diameters from 10 up to 125 mm with flange connections according to EN 1092-1.

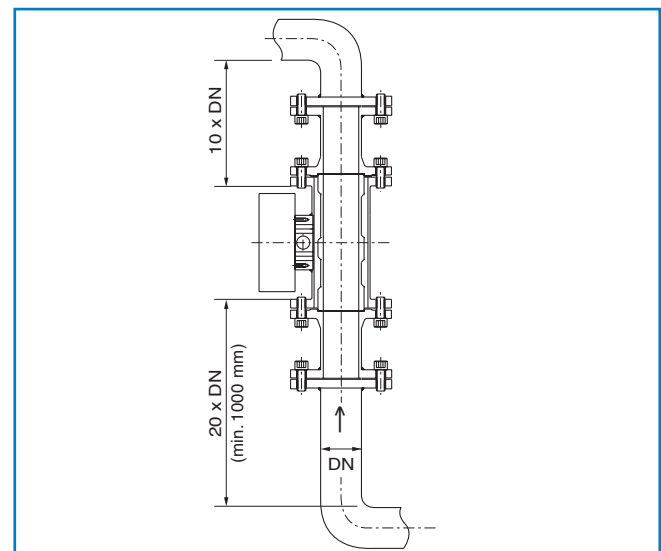

Technical data

Sensor	
Housing	Steel St 52, powder-coated (optional Stainless steel 1.4571 DN 10...125 mm (bigger diameters on demand) Flange EN 1092-1
Inner pipe	Ceramic
Protection category	IP 65
Ambient temperature	Sensor electronic: 0 ... +60 °C
Mediums temperature	Sensor pipe: 0 ... +80 °C (higher temperatures as option)

Working pressure	Max. 25 bar, optional 64 bar
Working frequency	88 kHz
Weight	Depending on the nominal diameter
Velocity range	1...10 m/s
Dimension	Ø DN + 150 mm, L 500 mm
Accuracy	± 2...5 % in calibrated range

Transmitter (DIN Rail)	
Power supply	24 V DC ±10 %
Power consumption	20 W / 24 VA
Protection type	IP 40 to EN 60 529
Ambient operating temperature	-10 ... +45 °C
Dimensions	23 x 90 x 118 mm (W x H x D)
Weight	Approx. 172 g
DIN rail fastening	DIN 60715 TH35
Connection terminals cable cross-section	0.2-2.5 mm ² [AWG 24-14]
Current output	1 x 4 ... 20 mA (0 ... 20 mA), load < 500 Ω
Interface	RS 485 (ModBus RTU) / USB
Pulse output	Open collector - max. 30 V, 20 mA
Relay contact	Max. rated load: 250 V AC Max. peak current: 6 A Max. rated load 230 V AC: 250 VA Max. breaking capacity DC1: 3/110/220 V: 3/0.35/0.2 A Min. switching load: 500 mW (10 V / 5 mA)
Data backup	Flash memory

Transmitter (field housing)	
Power supply	110 / 230 V AC 50 Hz (optional 24 V DC)
Power consumption	20 W / 24 VA
Protection type	IP 65 to EN 60 529/10.91
Ambient operating temperature	-10 ... +45 °C
Dimensions	258 x 237 x 174 mm (W x H x D)
Weight	Approx. 2.5 kg
Interface	RS 485 (ModBus RTU) / USB
Cable screw connectors	3 x M20 (4,5 - 13 mm Ø)
Connection terminals cable cross-section	0.2-2.5 mm ² [AWG 24-14]
Current output	3 x 4 ... 20 mA (0 ... 20 mA), load < 500 Ω
Pulse output	Open collector - max. 30 V, 20 mA
Relay contact	Max. rated load: 250 V AC Max. peak current: 6 A Max. rated load 230 V AC: 250 VA Max. breaking capacity DC1: 3/110/220 V: 3/0.35/0.2 A Min. switching load: 500 mW (10 V / 5 mA)
Data backup	Flash memory

